

Sand Filter
7024315

Technical Drawing

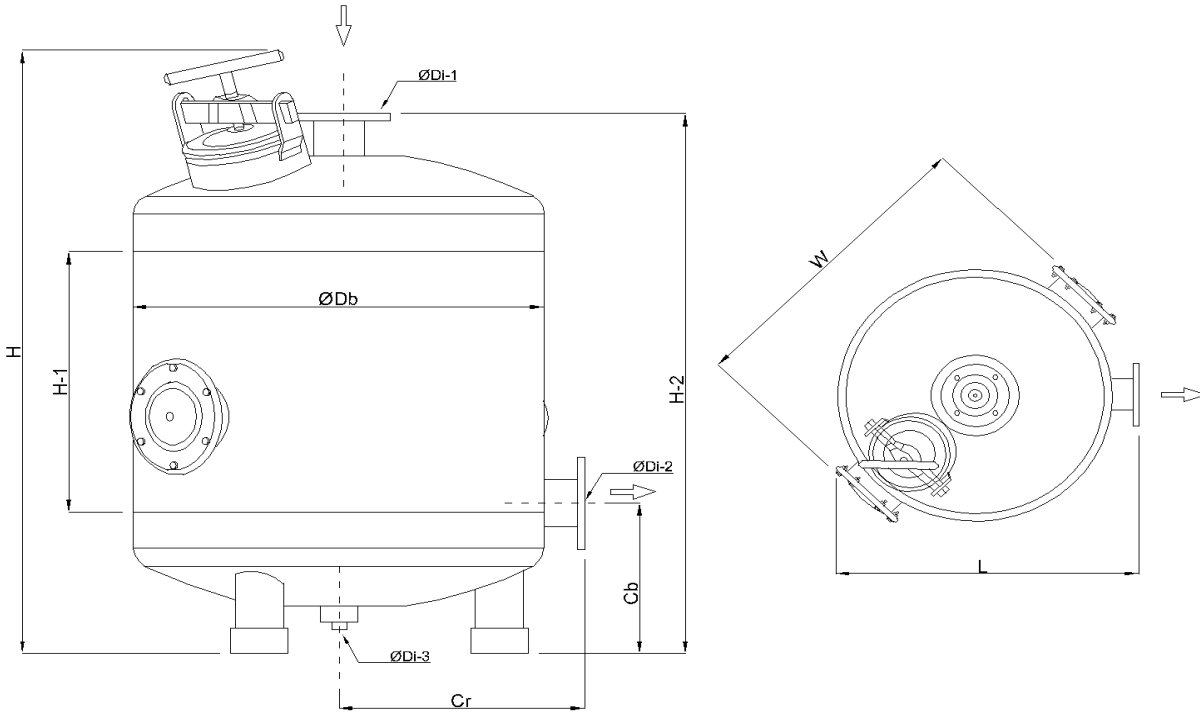

Table of size in (mm)

| Model | L | W | H | H-1 | H-2 | Cb | Cr | Db | Di-1 | Di-2 | Di-3 | Recom. Flow Rate (m ³ /h) | Backwash Flow Rate (m ³ /h) | Filtration area (m ²) | Weight Unit (kg) | No. Gravel bags of 25 kg |
|---------|-----|-----|------|-----|------|-----|-----|-----|------|------|------|--------------------------------------|--|-----------------------------------|------------------|--------------------------|
| 7024315 | 825 | 864 | 1197 | 518 | 1070 | 300 | 445 | 30" | 3" | 3" | 2" | 20-30 | 38 | 0.44 | 130 | 12 |