

SCALA

Multistage centrifugal boosters, 50/60 Hz



1. Product introduction	3	9. Grundfos Product Center	34
Applications	3	10. Document quality feedback	35
Features and benefits	3		
Pumped liquids	4		
Product range	4		
Performance range	5		
2. Selection guide	6		
3. Installation and operation	7		
Mechanical installation	7		
Installation examples	8		
Electrical connection	11		
Motor protection	11		
4. SCALA1	12		
Product range	12		
Motor	12		
Features and benefits of SCALA1	12		
Protection features	12		
Performance curves	13		
Technical data	16		
Approvals and markings	19		
Suction performance	20		
5. SCALA1 twin booster system	21		
Features and benefits	21		
Protection features	21		
Operating modes	21		
Performance curves	22		
Technical data	23		
6. SCALA2	24		
Product description	24		
Motor	24		
Features and benefits	24		
Perfect water pressure	24		
Low noise	24		
High energy efficiency	24		
Compact and easy to install	24		
Self-priming	24		
Robust design	24		
Protection features	24		
Performance curves	25		
Technical data	26		
Approvals and markings	28		
Suction performance	28		
7. Accessories	29		
SCALA twin accessory set	29		
SCALA2 accessories	30		
8. Product numbers	32		
SCALA1	32		
SCALA2	33		

1. Product introduction



Left to right: SCALA1, SCALA2

Grundfos SCALA pumps are all-in-one integrated pressure boosters designed for domestic use and ensure a constant supply of clean water to households, gardens and light commercial applications.

SCALA1

Grundfos SCALA1 is a self-priming, multistage pump, which combines all the components of a pressure booster into a compact composite enclosure.

SCALA1 can communicate with the Grundfos GO app through a built-in Bluetooth technology, which enables high customisation options, making this pump a good fit for every application.

SCALA2

Grundfos SCALA2 is a fully integrated, high-efficiency, self-priming pressure booster.

SCALA2 incorporates integrated speed control, enabling constant water pressure at the taps. The electronically controlled inverter limits the starting and operating currents, providing soft starts and high energy savings. The water-cooled motor and pump design offer a very low noise level down to 44 dB(A) in typical usage.

1.1 Applications

The SCALA boosters are suitable for domestic and light commercial water supply, where pressure boosting is required.

We recommend SCALA pumps for the following applications:

- pressure boosting of city mains water
- pressure boosting of water from roof tank
- pressure boosting of water from break tank
- pressure boosting of water from ground tank
- water supply from shallow wells [8 m (26.2 ft)]
- garden irrigation
- water transfer.

Depending on the application needs and required comfort, one pump can be a better fit than the other.

1.2 Features and benefits

General benefits of SCALA pumps:

- easy installation
- easy startup
- easy operation.

Features	SCALA1	SCALA2
Auto start-stop	√	√
Self-priming	√	√
Alarm indication	√	√
Dry-running protection	√	√
Anti-cycling protection	√	√
Maximum runtime protection	√	√
Bluetooth communication	√	-
Twin enabled	√	-
External input	√	-
Adjustable constant pressure	-	√
Integrated frequency converter	-	√
Low noise	55 dB(A)	44 dB(A) ¹⁾

¹⁾ 44 dB(A) is measured in a typical application with pressure control mode (2.5 bar (36 psi) and 1 m³/h).

1.3 Pumped liquids

The pump is designed for pumping clean, thin, fresh water with the following values:

	pH value	Max. chloride content	Max. free chloride content
SCALA1	4-7	50 ppm	0.2 ppm
SCALA2	4-9	300 ppm	1.0 ppm

Examples of pumped liquids:

- drinking or tap water
- rainwater
- groundwater
- river and lake water
- softened water.

Sand and other impurities in the water can cause wear to the pump and pump blockage. Therefore, we recommend that you install a filter on the inlet side or apply a floating strainer to protect the pump.

1.4 Product range

Pump type	Nominal flow rate [m ³ /h (gpm)]	Max. head [m (ft)]
SCALA1 3-25	3 (13)	25 (82)
SCALA1 3-35	3 (13)	35 (114)
SCALA1 3-45	3 (13)	45 (147)
SCALA1 5-25	5 (22)	25 (82)
SCALA1 5-35	5 (22)	40 (131)
SCALA1 5-55	5 (22)	55 (180)
SCALA2 3-45	3 (13)	45 (147)

1.5 Performance range

The performance curves show the range of the SCALA pumps.

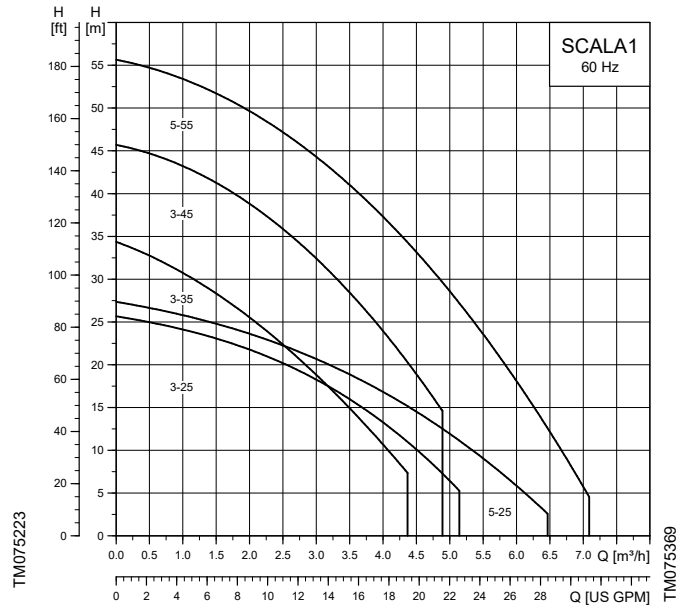
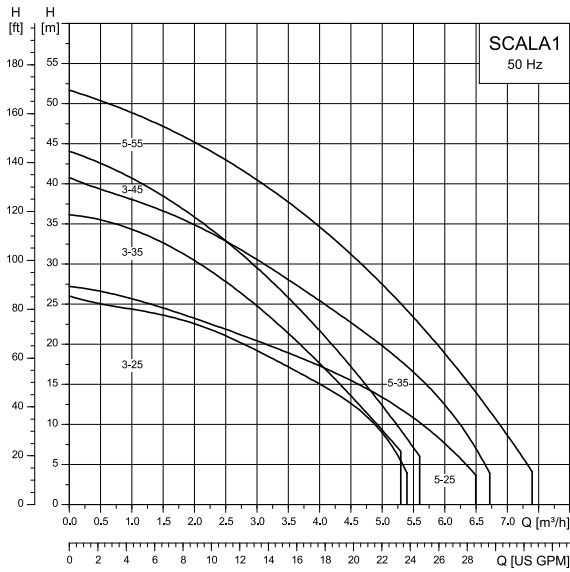

Performance range, SCALA1 50 Hz

Performance range, SCALA1 60 Hz

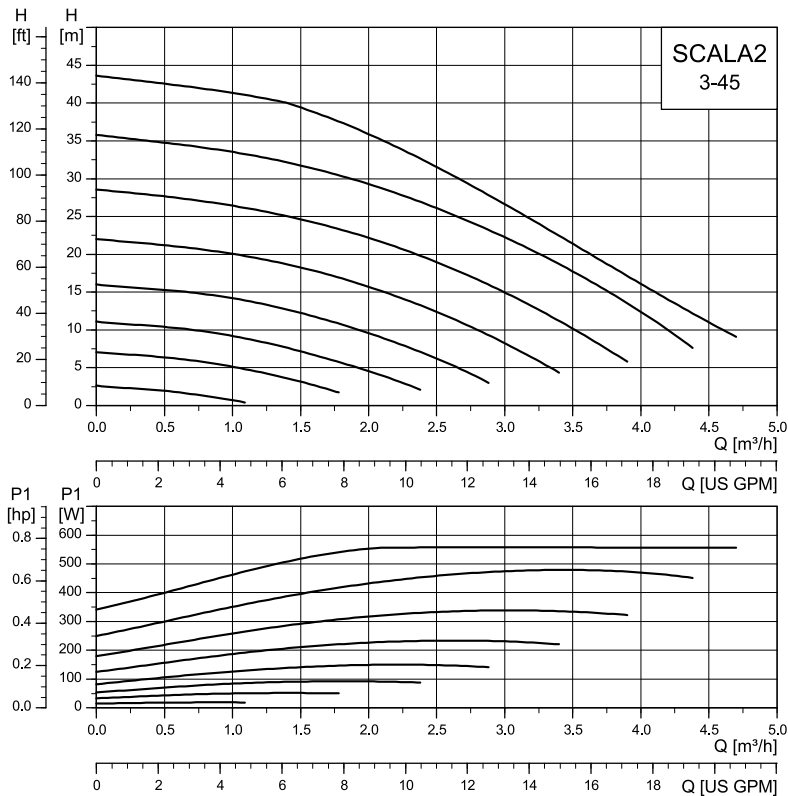

Performance range, SCALA2 50/60 Hz

TM1040350

2. Selection guide

This guide helps you to size and select the most suitable SCALA product.

Follow the instructions below to determine which product variant is best suited to your needs.

1. Choose the right pump for your application.

Application	Pump	Suitability rating	Recommendation
City water mains	SCALA1	• •	
	SCALA2	• • •	Due to integrated frequency converter, SCALA2 can adapt the speed to varying water pressure in the city mains, delivering constant pressure in all taps any time. PN10 rating ensures robustness towards maximum system pressure.
Shallow well	SCALA1	• • •	SCALA1 construction offers better suction capabilities with different modes to handle air.
	SCALA2	• •	
Water storage tank (above ground level)	SCALA1	• •	
	SCALA2	• • •	Adjustable constant pressure for SCALA2 enables user to select the desired pressure for the entire home, and thus avoids overpressure.
Water storage tank (below ground level)	SCALA1	• • •	SCALA1 construction offers better suction capabilities with different modes to handle air.
	SCALA2	• •	
Roof tank	SCALA1	• •	
	SCALA2	• • •	Adjustable constant pressure for SCALA2 enables user to select the desired pressure for the entire home, and thus avoids overpressure.
Water transfer	SCALA1	• • •	External input and fixed speed in SCALA1 will make sure water is transferred as quickly as possible from point A to B, when needed.
	SCALA2	•	
Garden irrigation	SCALA1	• • •	External input and calendar function are a perfect combination for irrigation purposes.
	SCALA2	•	
Kitchen	SCALA1	• •	
	SCALA2	• • •	SCALA2 delivers constant pressure to all taps regardless of the inlet pressure.
Bathroom	SCALA1	• •	
	SCALA2	• • •	SCALA2 delivers constant pressure to all taps regardless of the inlet pressure.

2. Size your pump.

Number of floors	1-5 taps	6-10 taps	11-20 taps	21-50 taps
4	SCALA1 3-45 or SCALA2 3-45	SCALA1 5-55	SCALA1 Twin 5-55	SCALA1 Twin 5-55
3	SCALA1 3-45 or SCALA2 3-45	SCALA1 3-45 or SCALA2 3-45	SCALA1 5-55	SCALA1 Twin 5-55
2	SCALA1 3-35 or SCALA2 3-45	SCALA1 3-45 or SCALA2 3-45	SCALA1 5-55 or SCALA1 5-35	SCALA1 Twin 5-55 or SCALA1 5-35
1	SCALA1 3-25 or SCALA2 3-45	SCALA1 3-35 or SCALA2 3-45	SCALA1 3-45 or SCALA2 3-45	SCALA1 Twin 5-55 or SCALA1 5-35

Preconditions:

- A tap pressure of 3 bar (43.5 psi) is considered. To achieve pressure of 4 bar (58 psi), remove two floors.
- The inlet is flooded. For suction operation, remove a floor for every 3 metres (9.84 ft) of suction depth.
- A tap flow between 9 (2.4 gpm) and 12 l/min (3.2 gpm) average usage and half of the taps opened at the same time will be considered.

3. Installation and operation

3.1 Mechanical installation

Placing the pump above ground is generally a convenient way to establish water or rainwater supply. The pump can be installed both indoors and outdoors.

The product should be placed as close as possible to the liquid to be pumped to minimize the length of the inlet pipe. The motor is water-cooled, but we still recommend a clearance of 0.5 m (1.64 ft) on three sides of the product.

The product should be fastened to a solid horizontal foundation with a maximum inclination angle of $\pm 5^\circ$. The base plate must be facing downwards.

If the pump is used for pumping rainwater or well water, we recommend installing a filter on the inlet side to protect the pump from sand, gravel or other debris. If the pump is installed above the liquid level, we recommend fitting a foot valve with a strainer to the inlet pipe.

3.1.1 Pipe system

To obtain the optimum suction capacity which the dry-installed pump is designed for, the correct dimension of the pipe system is important. If a hose is used as inlet pipe, it must be non-collapsible.

The diameter of the inlet pipe must be larger than 1", if the inlet pipe is longer than 10 m (32.8 ft), or if the suction lift exceeds 4 m (13.1 ft).

3.1.2 Inlet pipe length and suction lift

The length of the inlet pipe of self-priming pumps depends on the geodetic suction lift. The recommended maximum length of the inlet pipe according to the suction lift is shown in the figure below. The example shows that if the suction lift is 2.5 m (8.2 ft), the length of the inlet pipe must not exceed 25 m (82 ft).

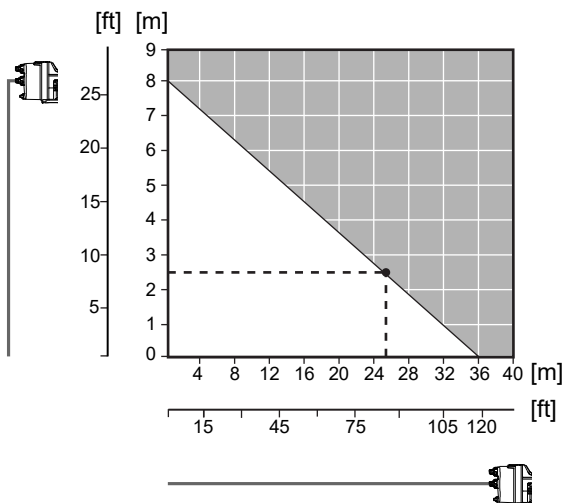

Maximum inlet pipe length (horizontal axis) according to the suction lift (vertical axis)

3.1.3 Inlet and outlet pipes

Follow these general precautions when connecting the inlet and outlet pipes.

! Do not let the pump support the pipes. Use pipe hangers or other supports at proper intervals to provide pipe support near the pump.

! The internal diameter of the pipes must never be smaller than the diameter of the pump ports.

- Install the pipes so that air pockets are avoided, especially on the inlet side of the pump.
- Use eccentric reducers with the tapered side down.
- Make sure the pipes are as straight as possible to avoid unnecessary bends and fittings. We recommend long-radius 90° pipe bends to decrease friction loss.
- Run the inlet pipe as direct as possible and, ideally, make sure that the length is at least ten times the pipe diameter.
- If possible, run a horizontal inlet line. We recommend a gradual upward slope for pumps operating in suction-lift conditions.
- A short pipe must be of the same diameter as the inlet port or larger.
- A long pipe must be one or two sizes larger than the inlet port, depending on the length.

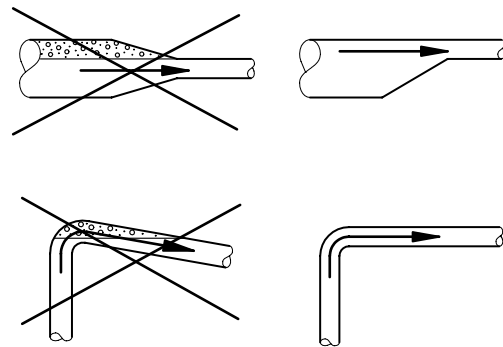

Recommended pipe installation to avoid friction and air pockets

TM040338

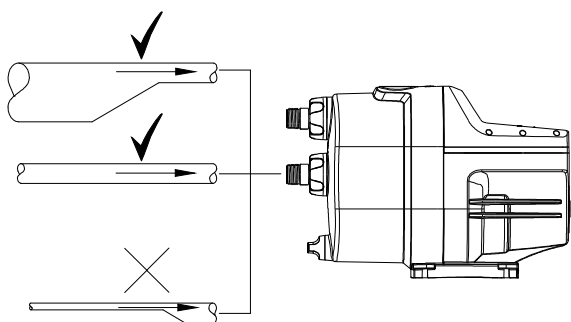

Correct pipe sizing for connection to the pump inlet or outlet

3.1.4 Maximum system pressure

The system in which the pump is installed must be designed to handle the maximum pump pressure.

The maximum inlet pressure must not exceed 6 bar, and the maximum system pressure must not exceed 10 bar.

When using the pump in installations with water heaters, you must use a non-return valve, pressure-relief valve or a thermal expansion tank between the pump and the water heater. This prevents the backflow pressure from exceeding the 10 bar pressure limit the pump is designed for.

3.2 Installation examples

We recommend that you follow the installation examples. Valves are not supplied with the pump.

3.2.1 Suction from a well

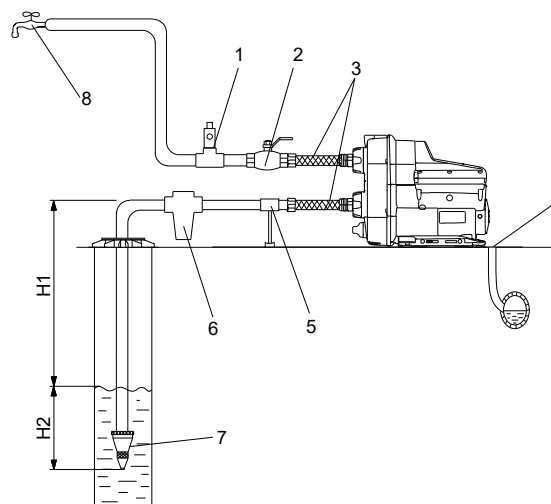

Suction from a well

Pos.	Description
1	Optional pressure-relief valve on the outlet side if the pressure can exceed 10 bar (145 psi).
2	Isolating valve
3	Flexible hoses
4	Drain to sewer
5	Pipe support
6	Inlet filter If the water may contain sand, gravel or other debris, install a filter on the inlet side to protect the pump and installation.
7	Foot valve with strainer (recommended)
8	Highest tapping point
H1	Maximum suction lift is 8 m (26 ft).
H2	Inlet pipe must be submersed at least 0.5 m (1.64 ft).

3.2.2 Suction from freshwater tank

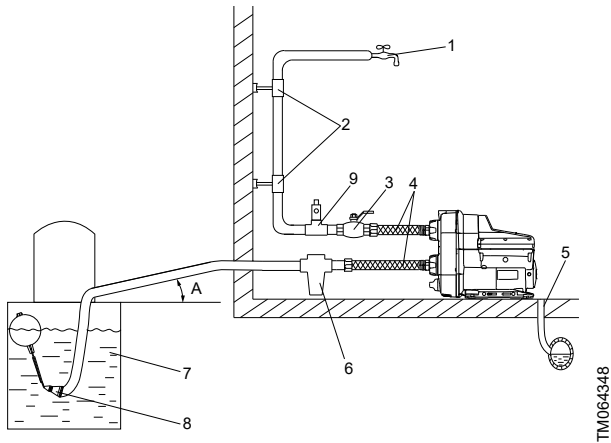

TM064348

Suction from freshwater tank

Pos.	Description
1	Highest tapping point
2	Pipe hangers
3	Isolating valve
4	Flexible hoses
5	Drain to sewer
6	Inlet filter. If the water may contain sand, gravel or other debris, please install a filter on the inlet side to protect the pump and installation.
7	Freshwater tank
8	Foot valve with strainer (recommended)
9	Optional pressure-relief valve on the outlet side if the pressure can exceed 10 bar (145 psi).
A	Minimum 1° inclination

3.2.3 Mains water pressure boosting

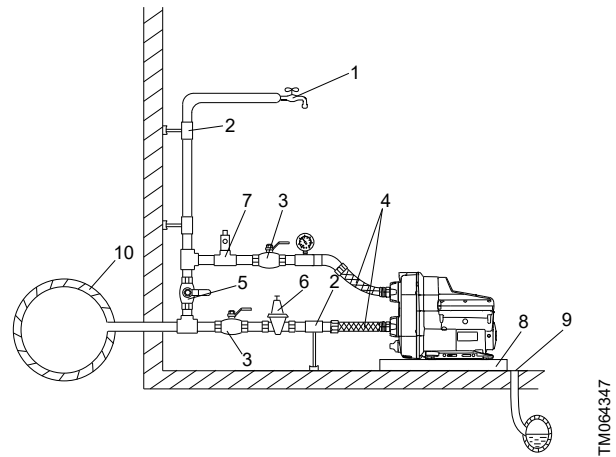

TM064347

Pos.	Description
1	Highest tapping point
2	Pipe hangers and supports
3	Isolating valves
4	Flexible hoses
5	Bypass valve
6	Optional pressure-reducing valve on the inlet side if the pressure can exceed: • SCALA1: 8 bar (115 psi) • SCALA2: 10 bar (145 psi).
7	Optional pressure-relief valve on the outlet side if the pressure can exceed: • SCALA1: 8 bar (115 psi) • SCALA2: 10 bar (145 psi).
8	Drip tray. Install the pump on a small stand to prevent the ventilation holes from being flooded.
9	Drain to sewer
10	Mains water pipe

3.2.4 Thermal expansion

When using SCALA in installations with water heaters, you must use a non-return valve, pressure-relief valve or a thermal expansion tank between SCALA and the water heater. This prevents the backflow pressure from exceeding the 10 bar pressure limit the pump is designed for.

When water is heated in a closed-loop system, its volume increases. A thermal expansion tank is most often used to absorb the additional volume created by this process. The small reservoir inside SCALA is built to prevent cycling and cannot compensate for thermal expansion.

Always consult the applicable water heater manufacturer specifications as installations may vary.

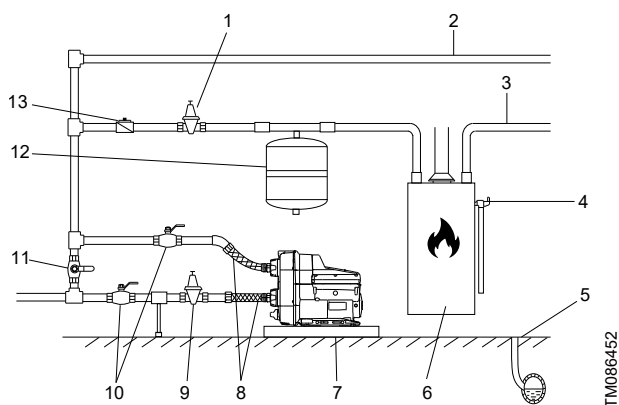

Installation example

Pos.	Description
1	Pressure-relief valve (optional)
2	Cold water
3	Hot water
4	Temperature and pressure valve
5	Drain to sewer
6	Water heater
7	Drip tray. Install the pump on a small stand to prevent the ventilation holes from being flooded.
8	Flexible hoses
9	Optional pressure-reducing valve on the inlet side if the pressure can exceed 10 bar (145 psi).
10	Isolating valves
11	Bypass valve
12	Expansion tank
13	Non-return valve

3.2.5 Roof tank filling

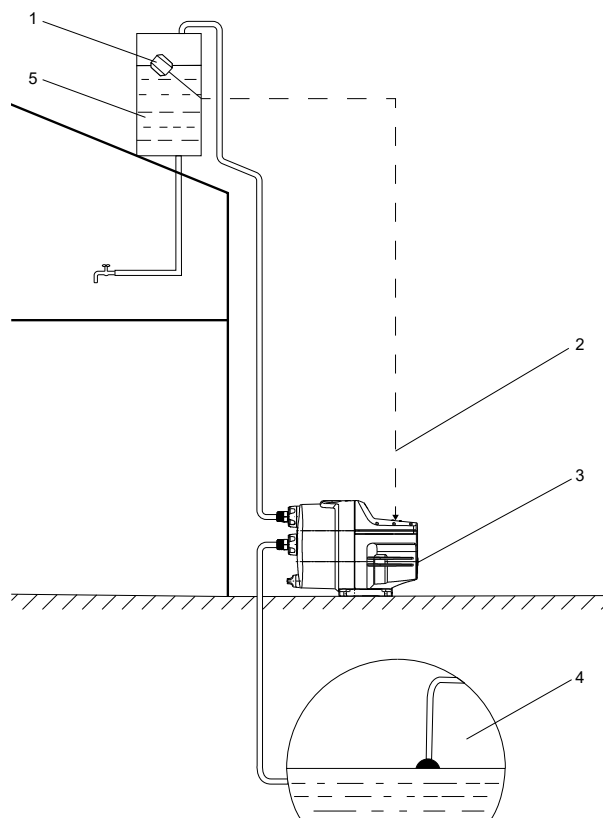

Pos.	Description
1	Float switch
2	External input (switch) cable
3	Pump
4	Water source (tank)
5	Roof tank

3.3 Electrical connection

The electrical connection and protection must be carried out in accordance with local regulations. Please also observe the following requirements:

- Make sure that the pump and pressure-control unit are suitable for the power supply to which they are to be connected.
- Make sure that the pump is suitable for the power supply to which they are to be connected.
- The pump and pressure-control unit must always be correctly earthed.
- The pump must always be correctly earthed.
- The plug on the pump must have the same protective earth (PE) connection system as the power outlet. If not, use a suitable adapter if allowed by local regulations.
- A pump without plug must be connected to an external main switch or wired with a plug.

3.4 Motor protection

The pump incorporates current- and temperature-dependent motor protection. If the pump is blocked or otherwise overloaded, the built-in thermal switch will cut out. When the motor has cooled sufficiently, it will restart automatically.

No external motor protection is required.

4. SCALA1



TM075390

SCALA1 pump

Grundfos SCALA1 is a self-priming, multistage pump, which combines all of the components of a pressure booster into a compact composite enclosure.

SCALA1 can communicate with the Grundfos GO Remote app through a built-in Bluetooth technology, which enables high customization options, making this pump a good fit for every application.

4.1 Product range

Pump type	Nominal flow rate [m ³ /h (gpm)]	Max. head [m (ft)]
SCALA1 3-25	3 (13)	25 (82)
SCALA1 3-35	3 (13)	35 (114)
SCALA1 3-45	3 (13)	45 (147)
SCALA1 5-25	5 (22)	25 (82)
SCALA1 5-35	5 (22)	35 (114)
SCALA1 5-55	5 (22)	55 (180)

4.2 Motor

The motor is water-cooled and equipped with sealed, greased-for-life ball bearings to ensure silent operation and minimum service. The motor has a built-in thermal switch and requires no additional motor protection.

4.3 Features and benefits of SCALA1

- Water on demand.
- All-in-one integrated booster.
- Bluetooth communication.
- External input.
- Twin booster enabled.
- Low noise level < 55 dB(A).

4.3.1 Self-priming

The self-priming function ensures a stable operation, even if the pump is not fully filled with liquid. The self-priming pump is able to lift liquid from below the inlet level and handle a mix of air and liquid until the pump reaches a fully-primed pumping condition.

4.3.2 Robust design

The pump is designed for long and trouble-free operation. Composite construction combined with excellent corrosion-resistant internal components ensure high robustness in operation.

4.3.3 Easy installation

All-in-one fully integrated plug-and-pump solution eliminating any uncertainties found in traditional installations.

4.4 Protection features

4.4.1 Dry-running protection

The product incorporates dry-running protection that automatically stops the pump from running without liquid. Dry-running protection means less risk of pump damage and lower maintenance costs.

4.4.2 Micro-leakage detection

The micro-leakage detection prevents the product from starting and stopping too often in case of a minor leakage in the system or if a tap has not been closed completely. The anti-cycling function will stop the pump, and an alarm will be indicated.

The factory setting for this function is on.

4.4.3 Maximum runtime

The maximum runtime function is a timer that can turn the pump off if it runs continuously for a certain amount of time. This time period is adjustable via Grundfos GO app.

4.5 Performance curves

50 Hz

60 Hz

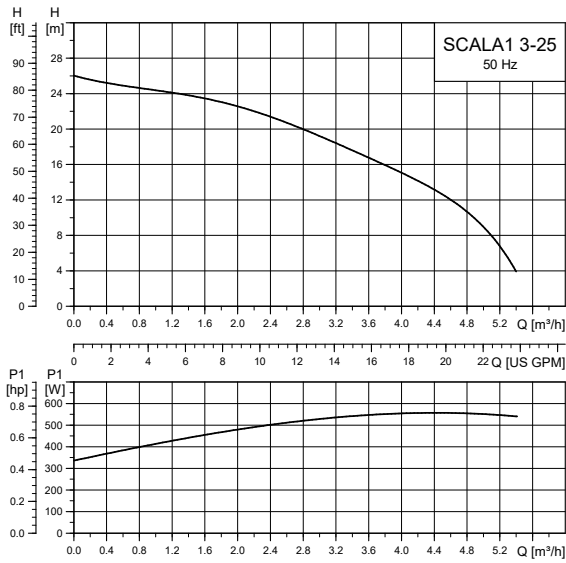

TM075218

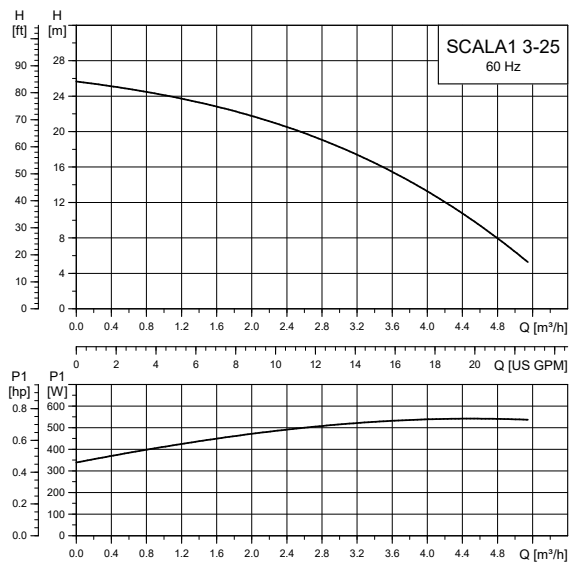

TM075364

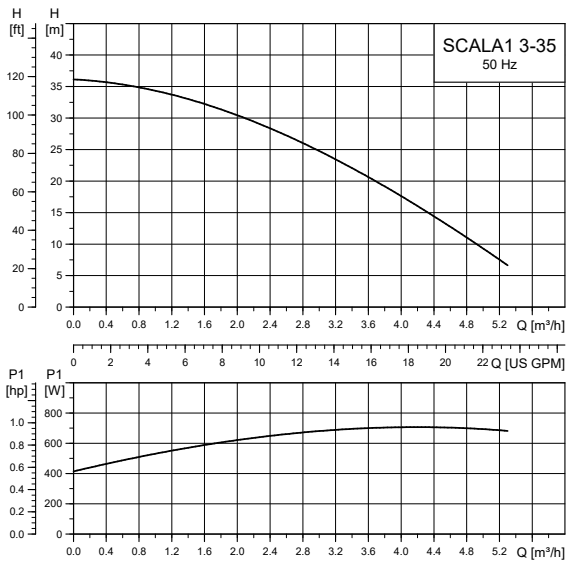

TM075219

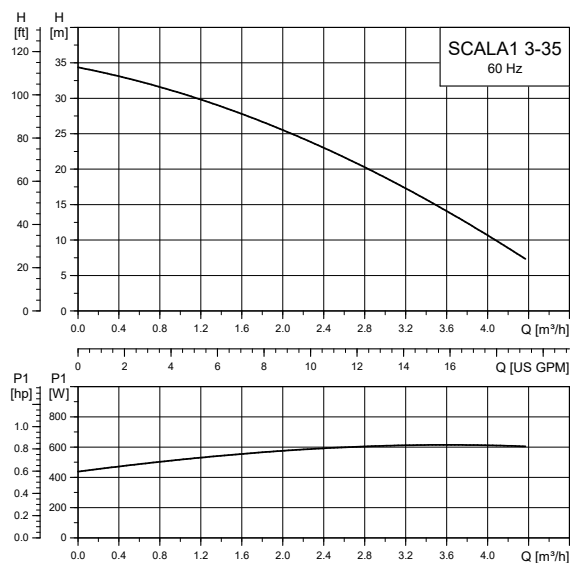

TM075365

50 Hz

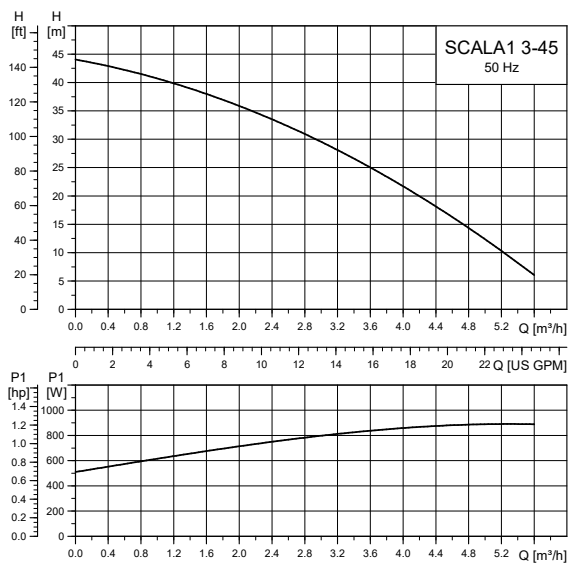

TM075220

60 Hz

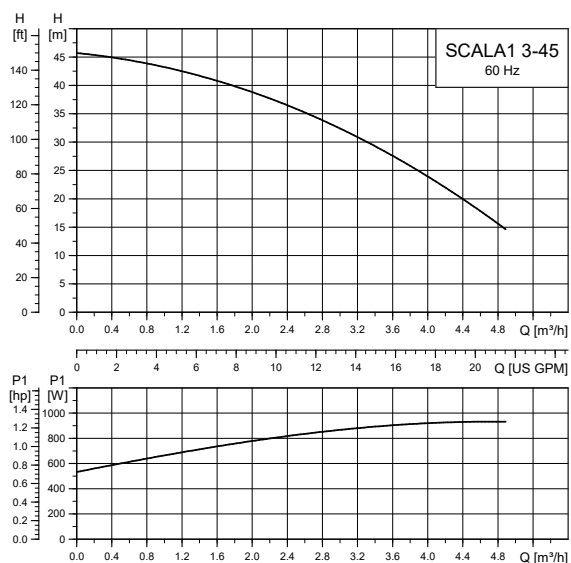

TM075366

50 Hz

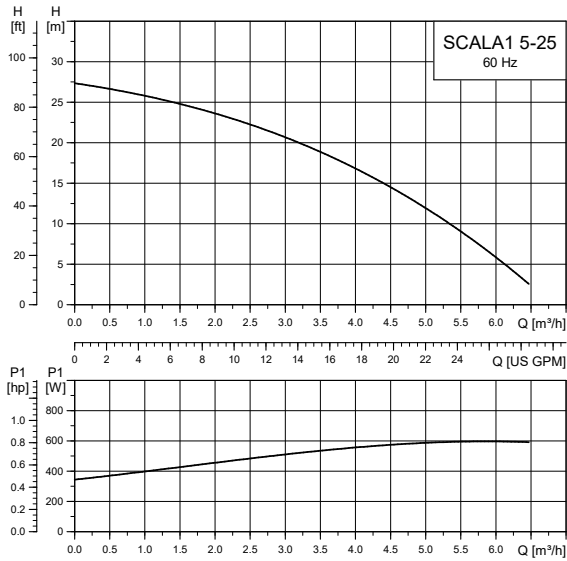

60 Hz

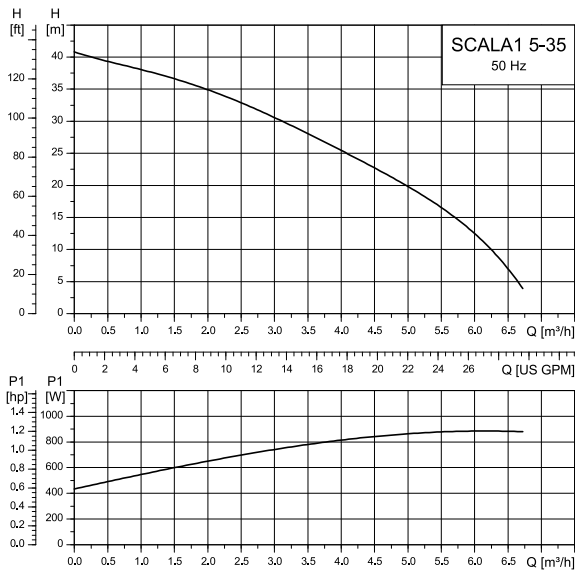
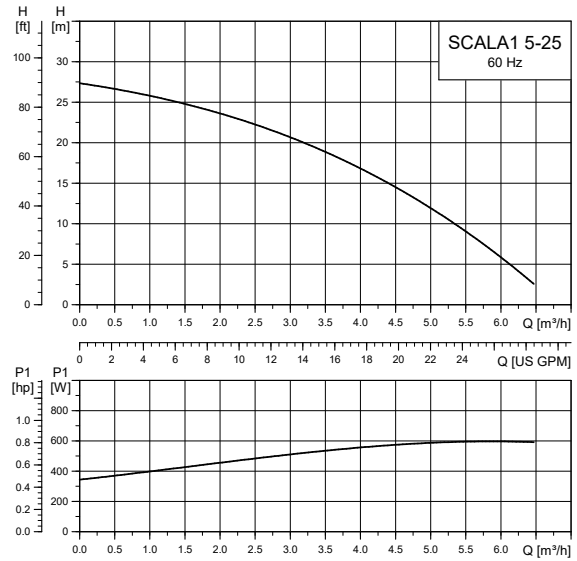

Product not available in 60 Hz

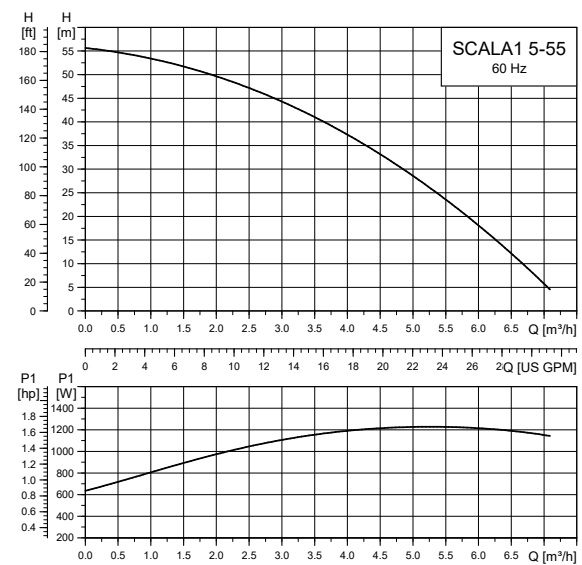
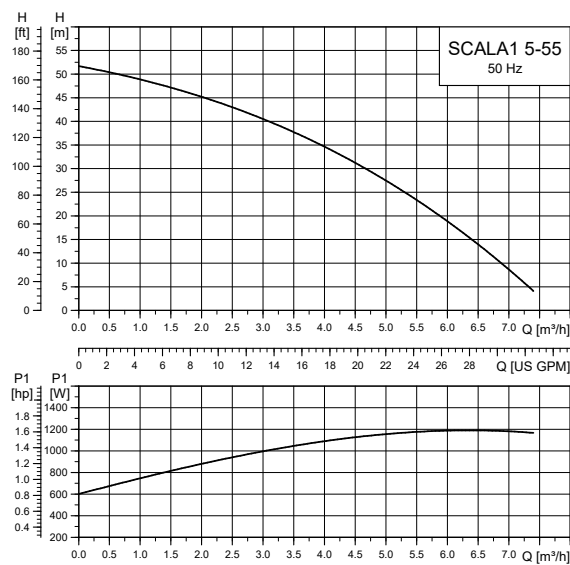

4.6 Technical data

4.6.1 Dimensions and weights

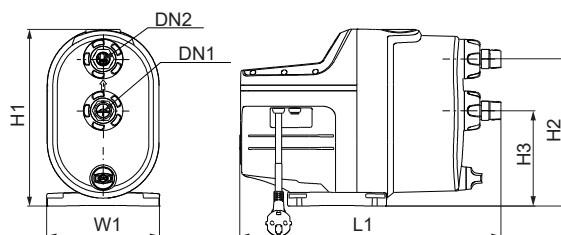

TM075267

Pos.	H1	H2	H3	L1	W1
	[mm] [inch]	[mm] [inch]	[mm] [inch]	[mm] [inch]	[mm] [inch]
SCALA1 (all variants)	316 12.4	263 10.4	171 6.7	466 18.4	202 8.0

Weight

SCALA1 3-25	SCALA1 3-35	SCALA1 3-45	SCALA1 5-25	SCALA1 5-35	SCALA1 5-55
[kg] [lb]	[kg] [lb]	[kg] [lb]	[kg] [lb]	[kg] [lb]	[kg] [lb]
11 24.2	12 26.4	12 26.4	12 26.4	12 26.4	14 30.8

4.6.2 Operating conditions

	SCALA1					
	3-25	3-35	3-45	5-25	5-35	5-55
Max. ambient temperature	55 °C (131 °F)	55 °C (131 °F)	55 °C (131 °F)	55 °C (131 °F)	55 °C (131 °F)	55 °C (131 °F)
Max. liquid temperature	45 °C (113 °F)	45 °C (113 °F)	45 °C (113 °F)	45 °C (113 °F)	45 °C (113 °F)	45 °C (113 °F)
Maximum system pressure [bar (psi)]	8 (116)	8 (116)	8 (116)	8 (116)	8 (116)	8 (116)
Maximum inlet pressure [bar (psi)]	5 (72.5)	4 (58)	3 (43.5)	5 (72.5)	4 (58)	2 (29)
Max. head [m (ft)] 50 Hz	25 (82)	36 (118.1)	44 (144.3)	26 (85.3)	40 (131.2)	52 (170.6)
Max. head [m (ft)] 60 Hz	25 (82)	35 (114.8)	46 (150)	27 (85.3)	-	55 (180)
Nominal head [m (ft)]	15 (49.2)	20 (65.6)	25 (82)	15 (49.2)	20 (65.6)	25 (82)
Nominal flow [m ³ /h (gpm)]	3.00 (12.19)	3.72 (16.38)	3.59 (15.80)	4.80 (21.12)	4.92 (21.66)	5.33 (23.48)
IP rating	X4D	X4D	X4D	X4D	X4D	X4D
Pumped liquids	Clean water	Clean water	Clean water	Clean water	Clean water	Clean water
Noise level [db(A)]	< 55	< 55	< 55	< 55	< 55	< 55
Frequency of starts and stops	25 per hour	25 per hour	25 per hour	25 per hour	25 per hour	25 per hour
Start pressure (pstart) [bar (psi)]	1.2 (17.4)	1.5 (21.8)	2.2 (31.9)	1.2 (17.4)	1.5 (21.7)	2.8 (40.6)

4.6.3 Electrical data

All variants have insulation class F.

50 Hz

Pump type	Voltage [V]	P1 [W (hp)]	P2 [W (hp)]	n [rpm]	I _n [A]	I _{start} [A]	Standby power [W]
SCALA1 3-25	1 × 230	550 (0.74)	360 (0.50)	2850	2.58	13.0	1.5
SCALA1 3-35	1 × 230	720 (0.97)	450 (0.60)	2800	3.27	13.0	1.5
SCALA1 3-45	1 × 230	910 (1.23)	580 (0.80)	2800	4.10	17.0	1.5
SCALA1 5-25	1 × 230	650 (0.88)	425 (0.60)	2850	3.00	13.0	1.5
SCALA1 5-35	1 × 230	890 (1.19)	450 (0.60)	2800	3.60	20.0	1.5
SCALA1 5-55	1 × 230	1200 (1.62)	780 (1.00)	2850	5.38	26.0	1.5

60 Hz

Pump type	Voltage [V]	P1 [W (hp)]	P2 [W (hp)]	n [rpm]	I _n [A]	I _{start} [A]	Standby power [W]
SCALA1 3-25	1 × 230	540 (0.72)	350 (0.50)	3450	2.37	13.0	1.5
	1 × 115	560 (0.75)	350 (0.50)	3450	5.10	29.5	1.5
SCALA1 3-35	1 × 230	650 (0.88)	470 (0.60)	3400	2.76	13.0	1.5
	1 × 115	650 (0.88)	470 (0.60)	3400	5.71	29.5	1.5
SCALA1 3-45	1 × 230	870 (1.17)	570 (0.80)	3350	3.72	15.5	1.5
	1 × 115	950 (1.28)	590 (0.80)	3400	8.62	40.0	1.5
SCALA1 5-25	1 × 230	600 (0.80)	420 (0.60)	3450	2.60	13.0	1.5
	1 × 115	610 (0.82)	450 (0.60)	3450	5.70	29.5	1.5
SCALA1 5-55	1 × 230	1250 (1.68)	810 (1.10)	3450	5.25	22.5	1.5
	1 × 115	1250 (1.68)	860 (1.10)	3450	11.57	64.0	1.5

4.6.4 Construction of SCALA1

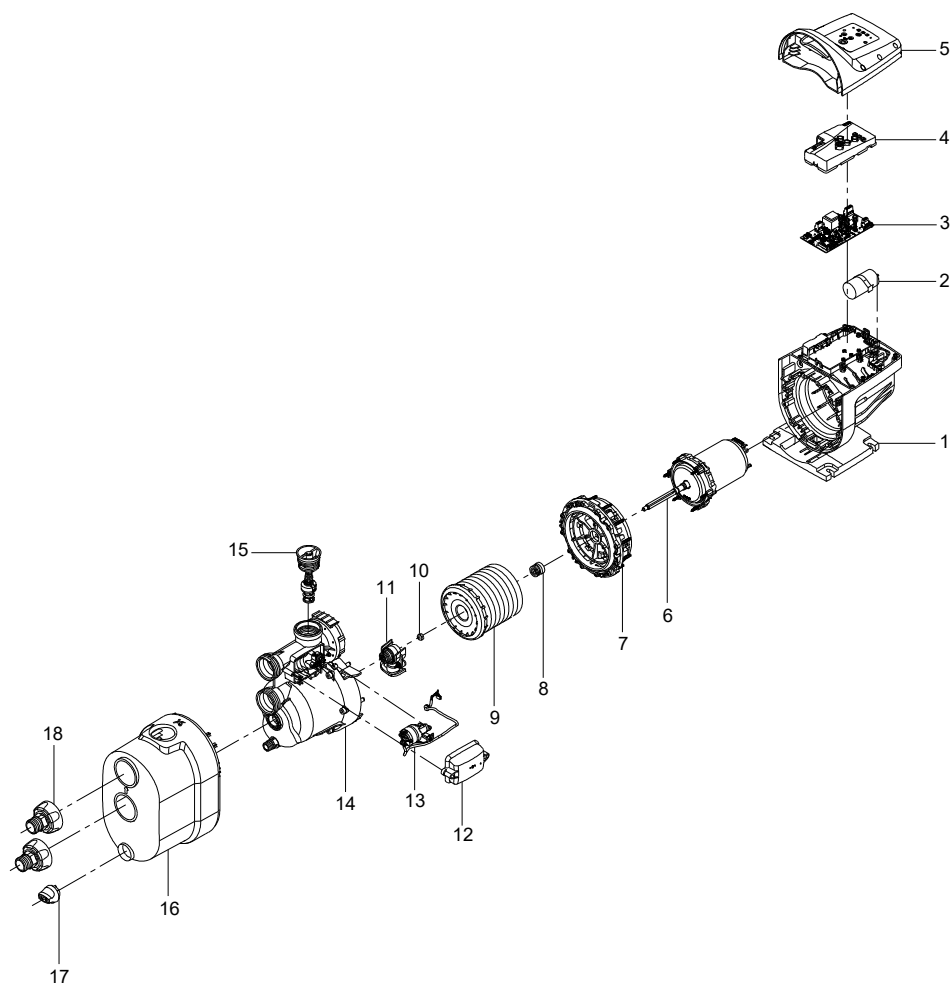

Exploded view of SCALA1

TM075375

Material specification

Pos.	Component	Material
1	Combined pump and stator housing	Composite
4	PCB cover	Composite
5	Cover for control box	Composite
6	Shaft	AISI 416 stainless steel
7	Motor flange	Composite
8	Shaft seal, complete	Carbon/Ceramic
9	Chamber stack	Composite
11	Air handling unit	Composite
14	Connection part for hydraulic	Composite
15	Non-return valve discharge	Composite
16	Cover for hydraulic	Composite
17	Drain plug	Composite
18	Fittings, thread R 1" / NPT 1"	Composite

4.7 Approvals and markings

Safety approvals



TM075405



TM074611



TM074115

Drinking water approvals



TM074613



TM074116

4.8 Suction performance

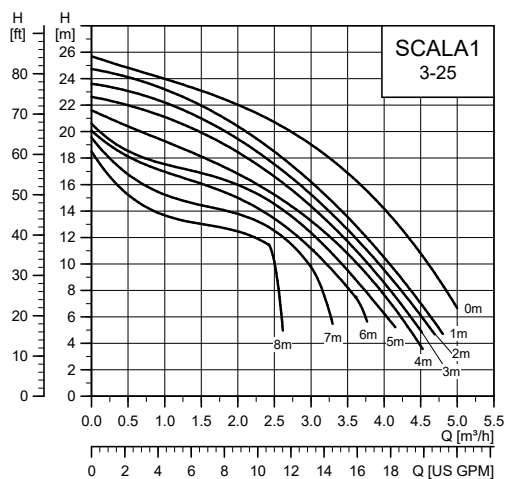

TM075531

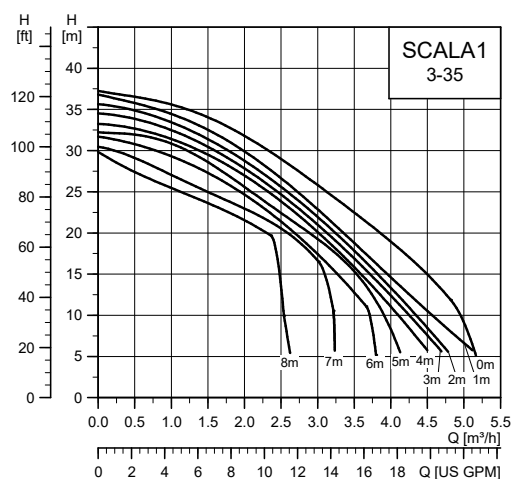

TM075532

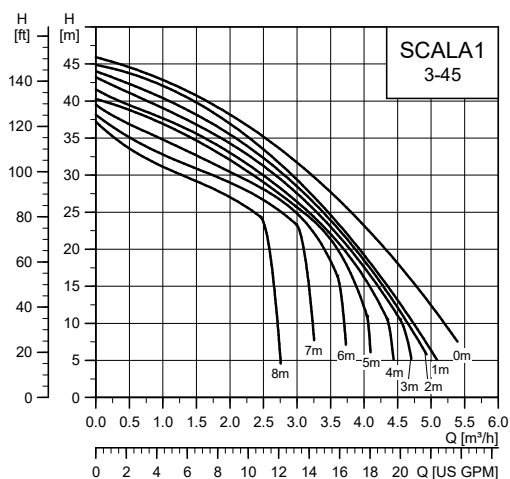

TM075533

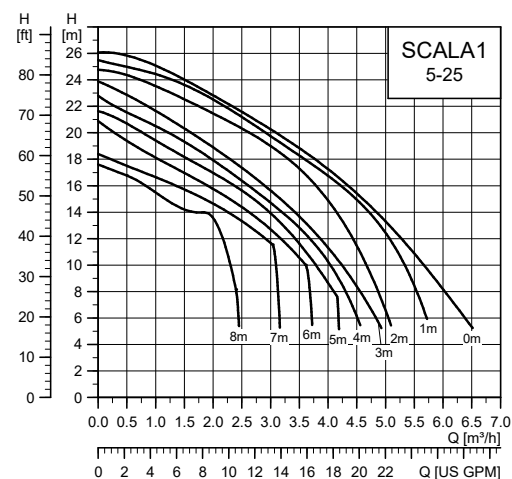

TM075534

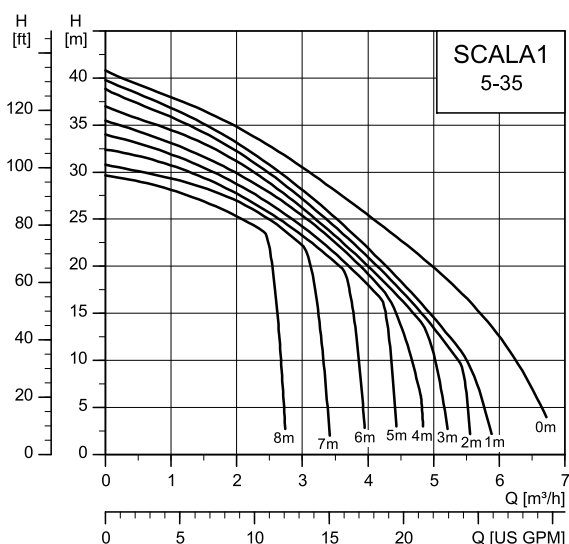

TM084481

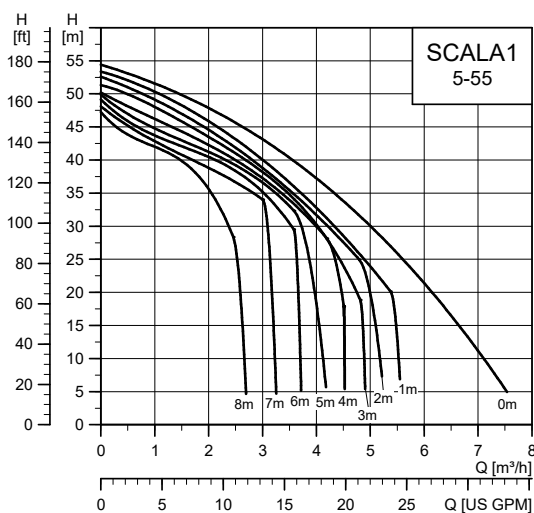

TM075535

5. SCALA1 twin booster system



TM075391

SCALA1 twin booster system

SCALA1 can be easily set as a twin booster, in case there is a need for a stand-by pump or higher flow demand.

For this purpose, there is a dedicated accessory set that includes:

- base plate
- inlet and outlet manifolds with valves
- communication cable
- fixing screws.

In the twin setup, the two SCALA1 pumps communicate together via a cable included in the accessory kit, enabling optimum double-pump operation.

5.1 Features and benefits

The twin system has all the features and benefits of the SCALA1 pump, along with the ability to handle increased flow demand.

5.1.1 Easy installation

SCALA1 twin booster can be quickly installed. After the pumps are mounted on the base plate and connected with a cable and manifolds, it is only a matter of connecting to the pipe system.

Once the system is primed, it is ready to deliver water.

5.1.2 Alternation

Once the communication cable is connected and the system powered on, the pumps are automatically assigned a priority at the start.

Alternation determines when the pumps will switch priority in starting, enabling equal use during operation lifetime. Grundfos GO Remote allows selecting the following options:

- alternate on runtime
- alternate on the number of starts.

Alternate on runtime

Pump 1 will be the first to start until it accumulates the defined number of running hours. After that, Pump 2 will start first.

Alternate on number of starts

Pump 1 will be the first to start until it accumulates the defined number of starts. After that, Pump 2 will start first.

5.1.3 Grundfos GO Remote enabled

SCALA1 twin booster system can be connected to Grundfos GO Remote via Bluetooth communication to be able to adjust the system parameters to specific user needs.

5.2 Protection features

SCALA1 twin booster has all the protective functions of the SCALA1 pump.

Dry-running protection will stop each pump separately, while the anti-cycling protection and maximum runtime protection will stop the system.

5.3 Operating modes

5.3.1 Duty/Assist

In Duty/Assist, both pumps can run at the same time, delivering more flow on the outlet side.

If one pump is unable to meet the demand, the second pump will start up.

5.3.2 Duty/Standby

In this mode, only one pump will run at a time, while the other pump will remain as a standby pump.

Based on alternation settings, the pumps will switch priority in starting.

5.4 Performance curves

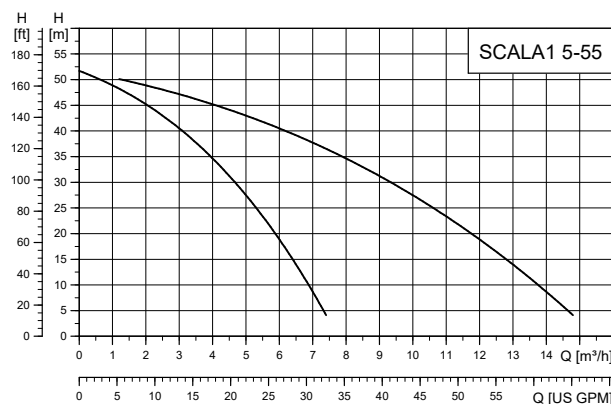
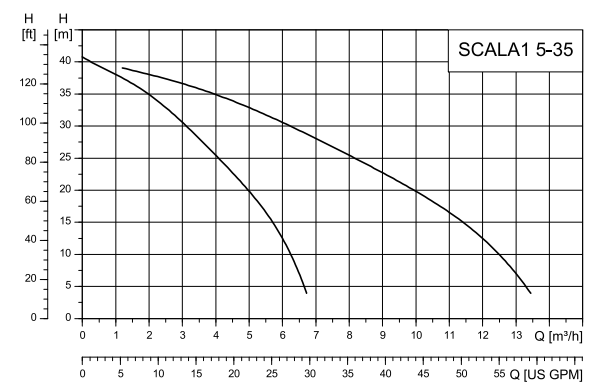
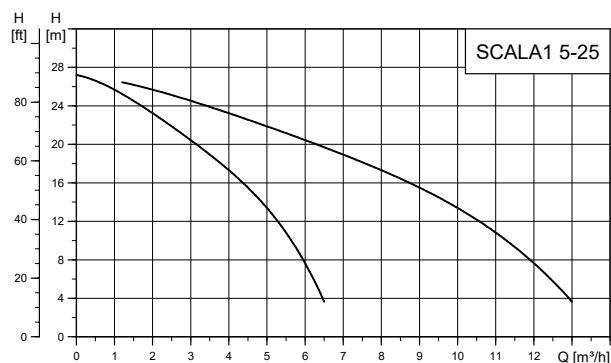
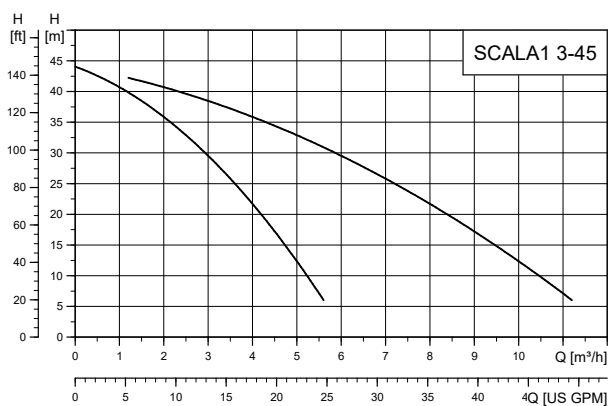
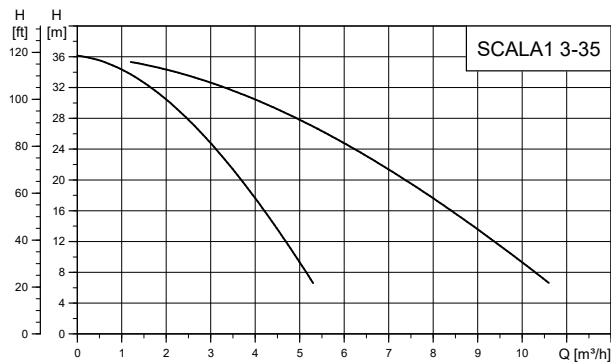
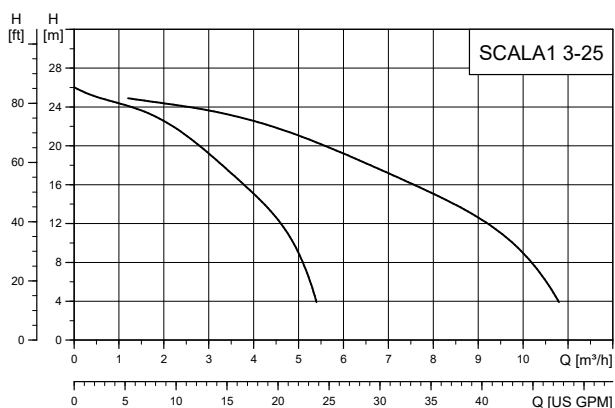

5.5 Technical data

5.5.1 Dimensions

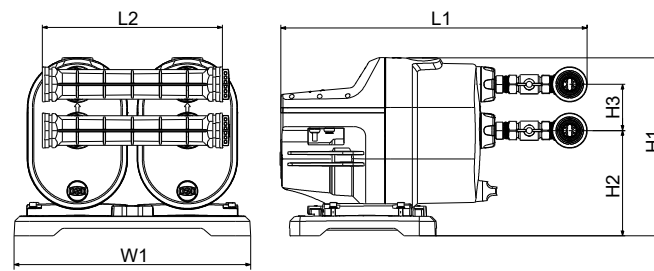

TM075401

Dimensions of SCALA1 twin system

	H1 [mm] [inch]	H2 [mm] [inch]	H3 [mm] [inch]	L1 [mm] [inch]	L2 [mm] [inch]	W1 [mm] [inch]
SCALA1 twin system	360 14.2	210 8.3	92 3.6	614 24.2	360 14.2	473 18.6

5.5.2 Construction of SCALA1 twin system

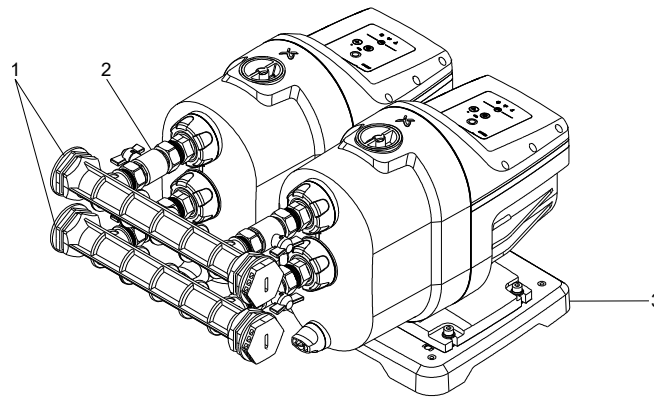

TM075400

SCALA1 twin system

Pos.	Component	Material
1	Inlet and outlet manifolds	Composite
2	Isolating valves	Brass
3	Twin base plate	Composite

6. SCALA2

6.1 Product description



TMO85689

Grundfos SCALA2 is a fully integrated, high-efficiency, self-priming pressure booster.

SCALA2 incorporates integrated speed control, enabling constant water pressure at the taps. The electronically controlled inverter limits the starting and operating currents, providing soft starts and high energy savings. The water-cooled motor and pump design offer a very low noise level down to 44 dB(A) in typical usage.

6.2 Motor

The highly efficient motor with a permanent magnet is water-cooled and equipped with sealed, greased-for-life ball bearings to ensure silent operation and minimum service.

It has a built-in thermal switch and requires no additional motor protection.

6.3 Features and benefits

6.4 Perfect water pressure

SCALA2 is equipped with an integrated sensor that measures the pressure discharged from the pump. The sensor sends a signal to the pump control and compares the measured pressure level with the desired pressure level, which is the pressure set according to the homeowner's needs.

If there is a difference between these two measurements, the pump control signals the frequency converter to increase or decrease the pump speed, thus maintaining a constant pressure in the system.

6.5 Low noise

SCALA2 stands out as one of the quietest boosters in its size category in the market. The motor is water cooled and equipped with sealed, greased-for-life ball bearings, ensuring silent operation with a noise level down to 44 dB(A) in typical usage.

6.6 High energy efficiency

SCALA2 is equipped with variable-speed drive which increases the entire pump system efficiency by eliminating wasted head and flow and allows the pump to operate closer to its best efficiency point (BEP).

6.7 Compact and easy to install

SCALA2 is an all-in-one fully integrated plug-and-pump solution, eliminating any uncertainties found in traditional installations. SCALA2 pumps can be installed in four easy steps:

1. Connect the pipes. The inlet and outlet connections are adjustable by up to 5°, making the installation even easier.
2. Prime the pump.
3. Plug the pump into a power outlet, and start the pump. The default pressure setting is 3 bar (43 psi).
4. Adjust the tank precharge pressure according to the setpoint.

6.8 Self-priming

The self-priming function ensures a stable operation, even if the pump is not fully filled with liquid. The self-priming pump is able to lift liquid from below the inlet level and handle a mix of air and liquid until the pump reaches a fully-primed pumping condition.

6.9 Robust design

The pump is designed for long and trouble-free operation. The aluminium pump and stator housing combined with excellent corrosion-resistant internal components ensure high robustness in operation.

6.10 Protection features

6.10.1 Dry-running protection

The product incorporates dry-running protection that automatically stops the pump from running without liquid. Dry-running protection means less risk of pump damage and lower maintenance costs.

The default setting for this feature is on and cannot be disabled.

6.10.2 Micro-leakage detection

The micro-leakage detection activates an alarm on the operating panel if the pump stops and starts too often. Frequent starts and stops can be caused by minor leakages in the system or if a tap has not been closed completely.

The default setting for this feature is off.

6.10.3 Maximum runtime

The maximum runtime function is a timer that can turn the pump off if it runs continuously for a certain amount of time. For SCALA2, this time period is 30 minutes.

The default setting for this feature is on.

6.11 Performance curves

The performance curves comply with ISO 9906 grade 2B.

50/60 Hz

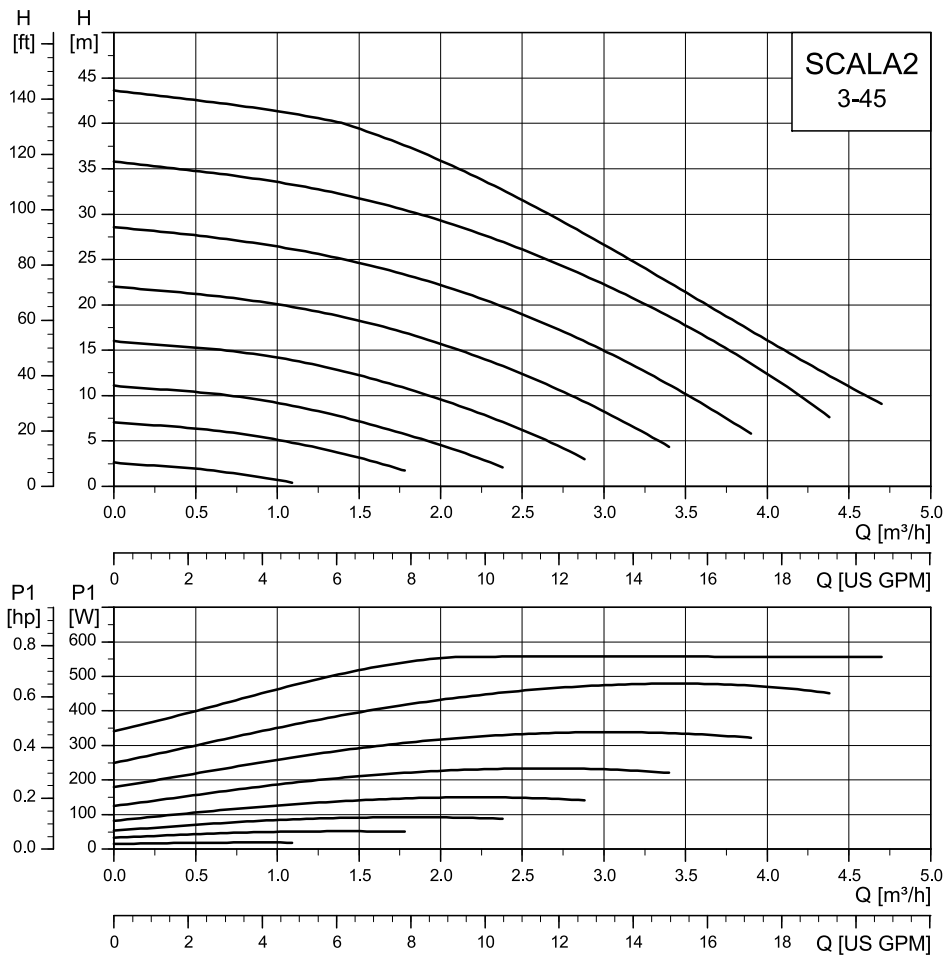

TM11040350

SCALA2 3-45 performance curves

6.12 Technical data

6.12.1 Dimensions and weights

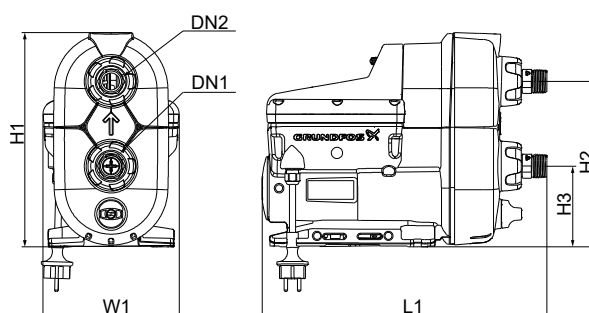

TM086088

Dimensions of SCALA2

	H1 [mm] [inch]	H2 [mm] [inch]	H3 [mm] [inch]	L1 [mm] [inch]	W1 [mm] [inch]	DN1	DN2	Weight [kg] [lb]
SCALA2	302 11.9	234 9.2	114 4.5	403 15.9	193 7.6	R 1 NPT 1"	R 1 NPT 1"	10 22

6.12.2 Operating conditions

Temperature	[°C (°F)]	
Max. ambient temperature		
1 × 208-230 V, 60 Hz:	45 (113)	
1 × 115 V, 60 Hz:	45 (113)	
1 × 200-240 V, 50/60 Hz:	55 (131)	
Max. liquid temperature	45 (113)	
Pressure	[bar (psi)]	[MPa]
Max. system pressure	10 (145)	1
Max. inlet pressure	6 (87)	0.6
Other operating data		
Max. head	45 m (147 ft)	
IP rating	X4D (outdoor installation)	
Pumped liquid	Clean water	
Noise level	< 44 dB(A) ²⁾	

²⁾ 44 dB(A) is measured in a typical application at duty point Q = 1 m³/h and H = 19 m in accordance with ISO 3745.

6.12.3 Electrical data

Supply voltage [V]	Frequency [Hz]	I _{max.} [A]	P1 [W]	Stand-by power [W]
1 × 200-240	50/60	2.8	550	2
				2
				2
				2
1 × 208-230	60	2.8	550	2
1 × 115	60	4.9	550	2

Supply voltage [V]	Frequency [Hz]	Plug
1 × 200-240	50/60	Schuko
		Schuko EAC
		Schuko SNI
		AUS
		UK
		ARG
		Chile
		Thailand
		India
		None
		No plug CN
		No plug AR1
		No plug AR2
		1 × 208-230
1 × 115	60	IEC, type B, NEMA 5-15P
		Japan
		None

6.12.4 Construction of SCALA2

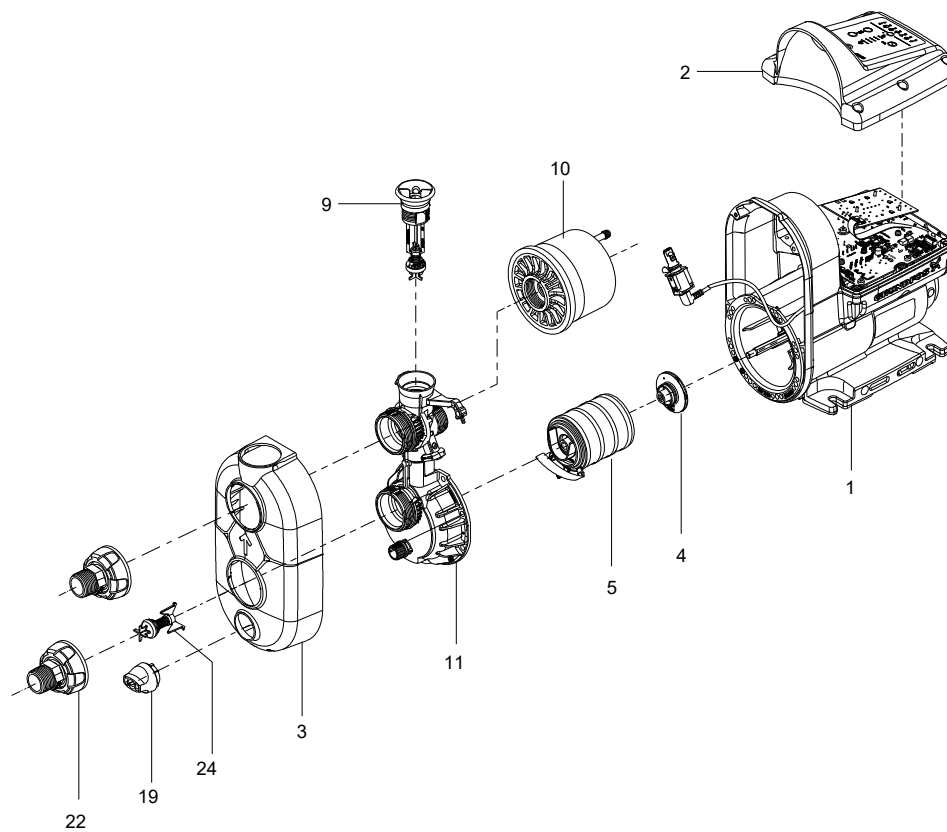

TM086154

Exploded view of SCALA2

Material specification

Pos.	Component	Material	Service part
1	Combined pump and stator housing	Aluminium, composite and EN 1.4301 / AISI 304	-
2	Control box cover	Composite	-
3	Pump cover	Composite	√
4	Shaft seal	Carbon/Ceramic	-
5	Chamber stack (four stages)	Composite	-
9	Non-return valve, outlet	Composite	√
10	Pressure tank complete	Composite, Butyl and EN 1.4301 / AISI 304	-
11	Connection part	Composite	-
19	Drain plug	Composite	√
22	Thread R 1" / NPT 1"	Composite	√
24	Non-return valve, inlet	Composite	√

6.13 Approvals and markings

Safety approvals



TM075405



TM075404



TM078367



TM074611



TM075835



TM065483



TM076456



TM081991

Drinking water approvals



WATER QUALITY
Drinking water system component
NSF/ANSI 61
NSF/ANSI 372

TM076608



TM074610

ACS

TM074613

Furthermore, the product has been approved in accordance with UBA and AWQC standards.

6.14 Suction performance

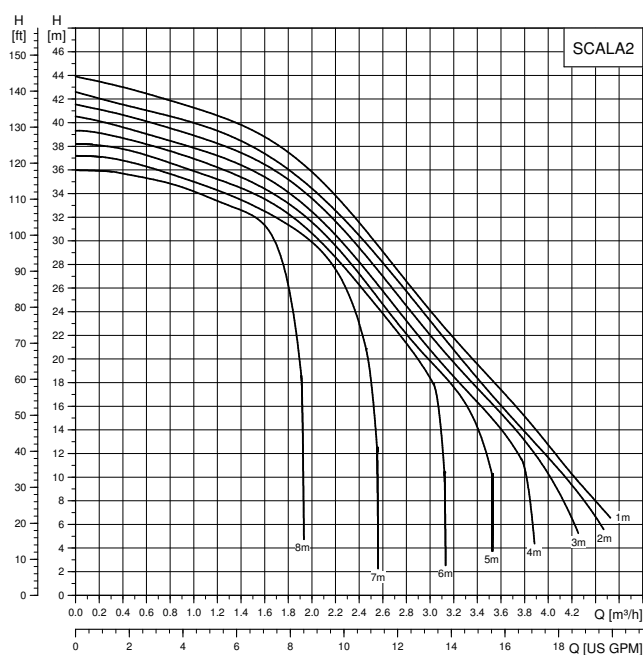

Suction performance for SCALA2

TM066277

7. Accessories

7.1 SCALA twin accessory set



TM075392

Twin accessory set

When an installation requires a two-pump solution, SCALA pumps can be easily connected using this set. It includes all the necessary components to set up SCALA pumps as a twin booster system.

This set includes:

- base plate
- two manifolds (inlet and outlet) including the isolating valves
- communication cable (for SCALA1 only)
- fixing screws.

7.1.1 Construction of SCALA twin accessory set

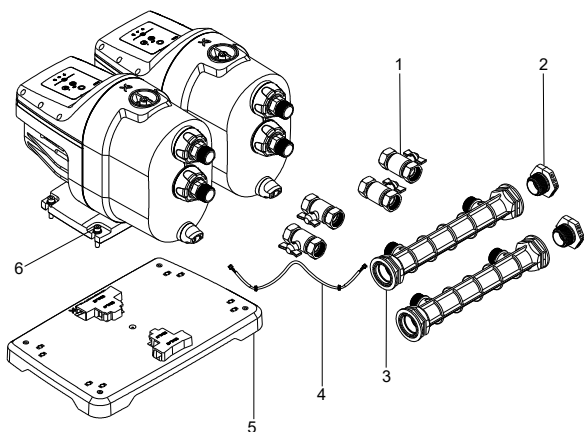

TM075402

Exploded view of SCALA twin accessory set

Pos.	Component	Material
1	Isolating valves	Brass
2	Manifold cap with O-ring	Composite, NBR
3	Inlet and outlet manifolds	Composite
4	Communication cable	-
5	Twin base plate	Composite
6	Fixing screws	Stainless steel

7.1.2 Product numbers

Description	Valve Connection	Manifold Connection	Part number
SCALA1 twin accessory set	1" Rp	1 1/4" Rp	99725165
SCALA1 twin accessory set	1" NPT	1 1/4" NPT	99725168
SCALA2 twin accessory set	1" Rp	1 1/4" Rp	99743076
SCALA2 twin accessory set	1" NPT	1 1/4" NPT	99743075

7.2 SCALA2 accessories

7.2.1 Flexible hoses



TM080290

The flexible hose range provides a safe and taint-free conveyance of potable water supplies in domestic and commercial applications. The range is designed to achieve robust and flexible solutions with the following attributes:

- Water Regulation Advisory Scheme (WRAS)-approved for both hot and cold water
- Strong construction with excellent abrasion and crush-resistant construction
- Excellent flexibility and kink resistance.

7.2.1.1 Product numbers

Description	Product number
Flexible hose set	99891639
Flexible hose set (with brass elbow connection)	99891647

7.2.2 Locking pin

The pump may produce a clicking noise if there is positive pressure at the inlet of the pump. In this case, you can mount a locking pin to avoid this noise. When a locking pin is mounted, the self-priming function is not applicable. If the pump has a negative pressure at the inlet, removing the locking pin is necessary to enable the self-priming function.

The pin is also available as an accessory.

Description	Product number
Locking pin SCALA2 (20 pieces)	99862078

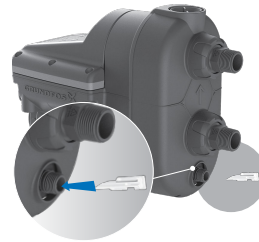

TM1040380

7.2.3 Inlet filter



TM075393

Inlet filter accessory

When using SCALA products for pumping rainwater or well water, we recommend installing a filter on the inlet side to provide clean water to increase the longevity of the pump, and to protect it from sand, gravel or other debris.

Features of the filter include:

- Clean water provides long life for the pump.
- Quick and easy installation.
- Easy maintenance and cleaning.

The square mesh allows a uniform flow along the entire surface of the cartridge itself, which minimizes the possibility of clogging. Also, the smooth surface of the filter ensures easy washing and cleaning. The filter cartridges provide a nominal filtration with an efficiency of 80 %. If properly used, they can be used repeatedly maintaining constant efficiency.

The inside core is manufactured from talc-filled polypropylene and a welded nylon net. The filter housing is composite.

7.2.3.1 Filter specifications

Micron rating	250
Efficiency percentage	80
Max. working pressure [bar (psi)]	8 (116)
Max. differential pressure [bar (psi)]	0.8 (11.6)
Max. working temperature	45 °C (113 °F)

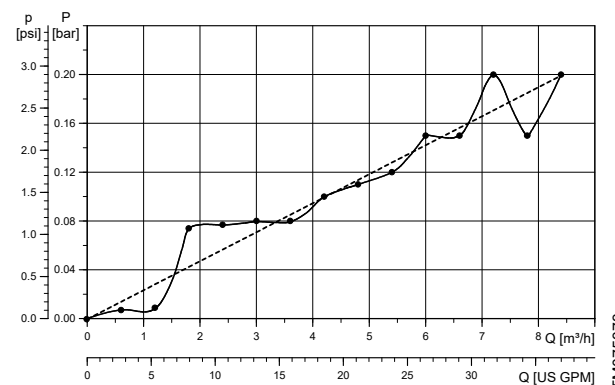

TM075373

Inlet filter pressure loss

7.2.3.2 Product numbers

Description	Connection	Part number
Inlet filter, 250 micron	1" Rp	99725183
Inlet filter, 250 micron	1" NPT	99725185

8. Product numbers

Guide on how to read the product number tables

Abbreviation	Description
SNI	Warranty card for Indonesia is included.
ARB	Printed installation and operating instructions in English (GB) and Arabic are included.
CCC	CCC approval on the nameplate.
CSA	CSA approval on the nameplate.

8.1 SCALA1

50 Hz

Pump model	Voltage	Plug type/cable	Country of origin	Product number
SCALA1 3-25	1 × 230 V 50	Schuko	Serbia	99530403
SCALA1 3-35	1 × 230 V 50	Schuko	Serbia	99530404
SCALA1 3-45	1 × 230 V 50	Schuko	Serbia	99530405
SCALA1 5-25	1 × 230 V 50	Schuko	Serbia	99530406
SCALA1 5-55	1 × 230 V 50	Schuko	Serbia	99530407
SCALA1 3-25	1 × 230 V 50	No plug	Serbia	99530408
SCALA1 3-35	1 × 230 V 50	No plug	Serbia	99530409
SCALA1 3-45	1 × 230 V 50	No plug	Serbia	99530410
SCALA1 5-25	1 × 230 V 50	No plug	Serbia	99530411
SCALA1 5-35	1 × 230 V 50	No plug	Serbia	92929476
SCALA1 5-55	1 × 230 V 50	No plug	Serbia	99530412
SCALA1 3-25	1 × 230 V 50	Thailand	Serbia	99530413
SCALA1 3-35	1 × 230 V 50	Thailand	Serbia	99530414
SCALA1 3-45	1 × 230 V 50	Thailand	Serbia	99530415
SCALA1 5-25	1 × 230 V 50	Thailand	Serbia	99530416
SCALA1 5-55	1 × 230 V 50	Thailand	Serbia	99530417
SCALA1 3-25	1 × 230 V 50	Australia	Serbia	99530418
SCALA1 3-35	1 × 230 V 50	Australia	Serbia	99530419
SCALA1 3-45	1 × 230 V 50	Australia	Serbia	99530420
SCALA1 5-25	1 × 230 V 50	Australia	Serbia	99530421
SCALA1 5-55	1 × 230 V 50	Australia	Serbia	99530422
SCALA1 3-25	1 × 230 V 50	UK	Serbia	99530423
SCALA1 3-35	1 × 230 V 50	UK	Serbia	99530424
SCALA1 3-45	1 × 230 V 50	UK	Serbia	99530425
SCALA1 5-25	1 × 230 V 50	UK	Serbia	99530426
SCALA1 5-55	1 × 230 V 50	UK	Serbia	99530427
SCALA1 3-25	1 × 230 V 50	Schuko SNI	Serbia	99530428
SCALA1 3-35	1 × 230 V 50	Schuko SNI	Serbia	99530429
SCALA1 3-45	1 × 230 V 50	Schuko SNI	Serbia	99530430
SCALA1 5-25	1 × 230 V 50	Schuko SNI	Serbia	99530431
SCALA1 5-55	1 × 230 V 50	Schuko SNI	Serbia	99530432
SCALA1 3-25	1 × 230 V 50	Argentina	Serbia	99656462
SCALA1 3-35	1 × 230 V 50	Argentina	Serbia	99656484
SCALA1 3-45	1 × 230 V 50	Argentina	Serbia	99656485
SCALA1 5-25	1 × 230 V 50	Argentina	Serbia	99656486
SCALA1 5-55	1 × 230 V 50	Argentina	Serbia	99656487
SCALA1 3-25	1 × 230 V 50	No plug CCC	Serbia	99530433
SCALA1 3-35	1 × 230 V 50	No plug CCC	Serbia	99530434
SCALA1 3-45	1 × 230 V 50	No plug CCC	Serbia	99530435
SCALA1 5-25	1 × 230 V 50	No plug CCC	Serbia	99530436
SCALA1 5-55	1 × 230 V 50	No plug CCC	Serbia	99530437

60 Hz

Pump model	Voltage	Plug type/cable	Country of origin	Product number
SCALA1 3-25	1 × 230 V 60	No plug ARB	Serbia	99530438
SCALA1 3-35	1 × 230 V 60	No plug ARB	Serbia	99530439
SCALA1 3-45	1 × 230 V 60	No plug ARB	Serbia	99530440
SCALA1 5-25	1 × 230 V 60	No plug ARB	Serbia	99530441
SCALA1 5-55	1 × 230 V 60	No plug ARB	Serbia	99530441
SCALA1 3-25	1 × 230 V 60	No plug	Serbia	99530443
SCALA1 3-35	1 × 230 V 60	No plug	Serbia	99530444
SCALA1 3-45	1 × 230 V 60	No plug	Serbia	99530445
SCALA1 5-25	1 × 230 V 60	No plug	Serbia	99530446
SCALA1 5-55	1 × 230 V 60	No plug	Serbia	99530447
SCALA1 3-25	1 × 230 V 60	NEMA 6-15 CSA	Serbia	99631734
SCALA1 3-35	1 × 230 V 60	NEMA 6-15 CSA	Serbia	99631735
SCALA1 3-45	1 × 230 V 60	NEMA 6-15 CSA	Serbia	99631736
SCALA1 5-25	1 × 230 V 60	NEMA 6-15 CSA	Serbia	99631737
SCALA1 5-55	1 × 230 V 60	NEMA 6-15 CSA	Serbia	99631739
SCALA1 3-25	1 × 115 V 60	No plug	Serbia	99530448
SCALA1 3-35	1 × 115 V 60	No plug	Serbia	99530449
SCALA1 3-45	1 × 115 V 60	No plug	Serbia	99530450
SCALA1 5-25	1 × 115 V 60	No plug	Serbia	99530451
SCALA1 5-55	1 × 115 V 60	No plug	Serbia	99530452
SCALA1 3-25	1 × 115 V 60	NEMA 5-15 CSA	Serbia	99631740
SCALA1 3-35	1 × 115 V 60	NEMA 5-15 CSA	Serbia	99631741
SCALA1 3-45	1 × 115 V 60	NEMA 5-15 CSA	Serbia	99631742
SCALA1 5-25	1 × 115 V 60	NEMA 5-15 CSA	Serbia	99631753
SCALA1 5-55	1 × 115 V 60	NEMA 5-15 CSA	Serbia	99631754

8.2 SCALA2**50/60 Hz**

Pump model	Voltage	Plug type/cable	Country of origin	Product number
SCALA2 3-45	208-230 V 60 Hz	NEMA 6-15	Serbia	93013250
SCALA2 3-45	115 V 60 Hz	NEMA 5-15	Serbia	93013251
SCALA2 3-45	200-240 V 50/60 Hz	Schuko	Serbia	93013252
SCALA2 3-45	200-240 V 50/60 Hz	No plug CN	Serbia	93013253
SCALA2 3-45	200-240 V 50/60 Hz	No plug	Serbia	93013254
SCALA2 3-45	200-240 V 50/60 Hz	Australia	Serbia	93013257
SCALA2 3-45	200-240 V 50/60 Hz	UK	Serbia	93013322
SCALA2 3-45	200-240 V 50/60 Hz	ARG	Serbia	93013418
SCALA2 3-45	200-240 V 50/60 Hz	Schuko EAC	Serbia	93013352
SCALA2 3-45	100-115 V 50/60 Hz	No plug	Serbia	93013353
SCALA2 3-45	200-240 V 50/60 Hz	Schuko SNI	Serbia	93013354
SCALA2 3-45	100-115 V 50/60 Hz	Japan	Serbia	93013355
SCALA2 3-45	200-240 V 50/60 Hz	Chile	Serbia	93013357
SCALA2 3-45	200-240 V 50/60 Hz	Thailand	Serbia	93013358
SCALA2 3-45	200-240 V 50/60 Hz	No plug AR1	Serbia	93013370
SCALA2 3-45	200-240 V 50/60 Hz	No plug AR2	Serbia	93050446
SCALA2 3-45	200-240 V 50/60 Hz	Indian plug	Serbia	93013371

9. Grundfos Product Center

Online search and sizing tool to help you make the right choice.

From the international view, you can select your specific country to view the product range available to you.

International view: <http://product-selection.grundfos.com>

All the information you need in one place

Performance curves, technical specifications, pictures, dimensional drawings, motor curves, wiring diagrams, spare parts, service kits, 3D drawings, documents, system parts. The Product Center displays any recent and saved items - including complete projects - right on the main page.

Downloads

On the product pages, you can download installation and operating instructions, data booklets, service instructions, etc., in PDF format.

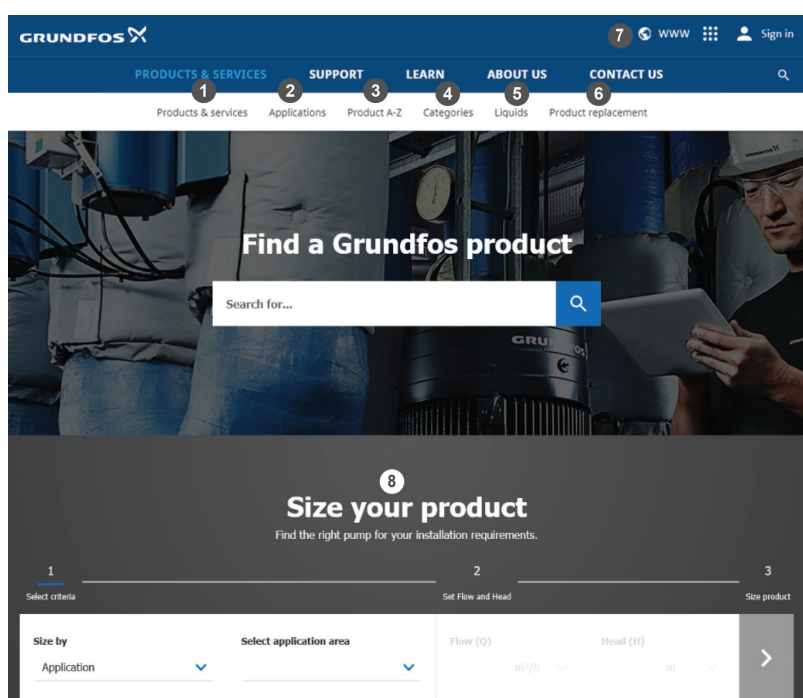
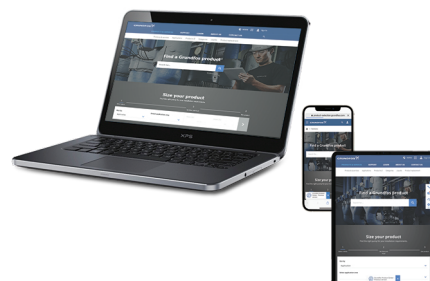

When you select your country, you will see the menus below. Note that some menus may not be available depending on the country.

Example: <https://product-selection.grundfos.com/uk>

Pos.	Description
1	Products & services enables you to find products and documents by typing a product number or name into the search field.
2	Applications enables you to choose an application to see how Grundfos can help you design and optimize your system.
3	Products A-Z enables you to look through a list of all the Grundfos products.
4	Categories enables you to look for a product category.
5	Liquids enables you to find pumps designed for aggressive, flammable or other special liquids.
6	Product replacement enables you to find a suitable replacement.
7	WWW enables you to select the country, which changes the language, the available product range and the structure of the website.
8	Sizing enables you to size a product based on your application and operating conditions.

10. Document quality feedback

To provide feedback about this document, scan the QR-code using your phone's camera or a QR code app.



[Click here to submit your feedback](#)

99735562

ECM: 1448577	03.2026
--------------	---------

Grundfos Holding A/S
Poul Due Jensens Vej 7
DK-8850 Bjerringbro
Tel: +45 87 50 14 00
www.grundfos.com

GRUNDFOS 