



70-120 M<sup>3</sup>



# WHISPERFLO® VS2

First-in-class hydraulic performances, modern design for the highest efficiency at low speed with very low energy consumption.

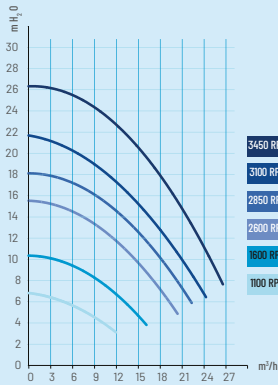

## FEATURES

- ¼ turn opening lid
- Quick self priming
- One-piece pump body
- Oversized and robust motor

## BENEFITS

- Easy opening and locking
- Quick and safe start of the pump
- Super silent
- Extremely reliable and efficient pump

## TECHNICAL FEATURES

- Oversized 3hp asynchronous motor derated to 1.5hp to deliver high efficiency even at high speed
- 3 programmable speed/time + override
- Simple and intuitive LCD display with Watts, RPM & time info
- 4 digital inputs for external control (optional communication cable - PN. 356324Z)
- Inlet/Outlet → 2" BSP tapped
- Ø Unions → 50 mm or 63 mm
- Unions included → Yes
- Salt resistancy → 0.40%

Part Number	Flow m <sup>3</sup> /h @ 8 m	Power output (kW)	(HP)	Volt (V)	Phase	Width (mm)	Length (mm)	Weight (Kg)	List Price (€ VAT excl)
<b>WFL-VS2</b>	<b>27</b>	<b>1.1</b>	<b>1.5</b>	<b>220-240</b>	<b>1~</b>	<b>275</b>	<b>560</b>	<b>24.5</b>	<b>1199</b>

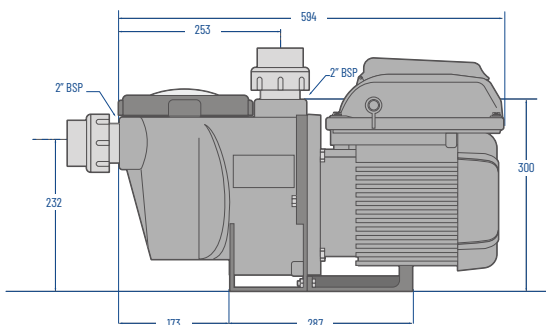

Packaging	Length (cm)	Width (cm)	Height (cm)	Pallet
Box	79	37	43	-
Pallet	120	80	150	9