

NORSUP CATALOGUE 2021

YOUR GUIDE TO INFINITE POOL ENJOYMENT!



NORSUP



NORSUP 2021

CONTENTS

1. THIS IS NORSUP	4
2. NORSUP PP/PE POOLS	6
3. POOL COVERS	14
3.1 Pool enclosures	16
3.2 Slatted covers	26
4. NORSUP TECHNICAL EQUIPMENT	28
4.1 Norsup pool plant tanks & splash water tanks	30
4.2 Norsup filters	32
4.3 Norsup pumps	38
4.4 Norsup heating	40
4.5 Norsup water treatment	48
4.6 Norsup controlling	50
4.7 Norsup cleaning	52
4.8 Norsup maintenance accessories	54
5. NORSUP SMART & CONVENIENT	56



1.

THIS IS NORSUP

BRINGING WATER TO THE NEXT LEVEL

MAKING THE UNREACHABLE REACHABLE

Combine the simplicity of water and a relaxing, luxury lifestyle with a pool in your garden. Norsup makes make luxury and high-quality products accessible to enrich lives and make the unreachable, reachable.

Norsup translates the simplicity and joy of water to high-quality products for pools and water technology that are as pure and simple as water itself. Together with smart applications in the palm of your hand, Norsup provides you clear service when it comes to installation and maintenance. Technology that allows you to operate and enjoy a carefree life more than ever, all within our vision and aim to find the best solutions that help to use water and energy in a sustainable and responsible way. Worry-free enjoyment awaits!

HIGH-END NORSUP RANGE

Norsup has the best pools, pumps, heat pumps, water treatment, cleaning robots, filters and controlling equipment . The range is expanding continuously with new products added regularly, with the goal to offer a complete range of high-quality pool materials to install from beginning to end. All products fit seamlessly to each other and guarantee a complete, perfectly operating system. All spare parts are delivered from stock for easy and fast maintenance.

Norsup works together with a number of innovative companies to develop new products, techniques and apps to offer you the convenience you need. With an in-house testing facility, Norsup constantly improves its state-of-the-art water technology, offering you the best range of high quality products.



EXCLUSIVELY AVAILABLE THROUGH **SELECTED DEALERSHIPS**

The Norsup range is exclusively available via a carefully selected dealer network. These are proven pool installers with a high service level and trained to fit and maintain Norsup products. Experts who understand the meaning and value of the Norsup products and not only take care of the installation of a pool and its components, but also the maintenance.

ADVANTAGES

- Higher margin
- Dealership exclusiveness - no online competition
- Lead generation (as dealer on Norsup website)
- Development of apps & configurators
- Remote maintenance opportunities
- Spare parts directly available for fast maintenance
- Fast service response time to questions and issues
- On-site repair
- Special Norsup training days & events
- Merchandising materials available for all dealers

INTERESTED?

For more information go to: www.norsup.eu or contact us: info@norsup.eu.
Norsup is a brand of Bosta and Bevo: www.bosta-bevo.eu.







2.

**NORSUP
PP/PE POOLS**

NORSUP PP/PE POOLS

With 25 years' manufacturing experience, by choosing top quality of materials, Norsup PP/PE pools ensure extended operation life and exceptional design. Norsup provides both standard pools and pools with a built-in roller shaft which is ideal for implementing submerged automatic pool covers. The pools are available in different sizes, wall thickness, several stair designs and colour options, customised for each customer and situation. Everything is pre-installed / assembled, which makes installation easier!



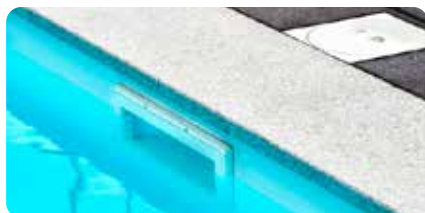

NORSUP 3 YEARS WARRANTY
 15 YEARS ON CONSTRUCTION
 10 YEARS ON WATERPROOFNESS

Every pool is custom made.
 Please contact our sales team for
 the different sizes and options.

COMPLETE PACKAGING SOLUTION

All pools are pre-installed with high water line skimmers, nozzles, lights and piping. Please check out our white goods and lights in the general pool catalogue to select your preferred products. Automatic pool covers are pre-designed to fit each pool. Please check out our Pool cover assortment to select your preferred pool covers.

FEATURES

- Solid construction with vertical struts with 50 cm distance, additional steel reinforcement and reinforcement at the top of the pool
- High quality polypropylene with 12 mm wall thickness, bottom 8 mm
- Insulation with 4 cm Polystyrol rigid foam panels
- 20 mm thick treads with anti-slip coating (always in white)
- Delivered pre-installed (saves time and money)

STEPS

Type	SEB5S	SED5S	SEA5S	SEC5S
Price (incl. VAT)				



COVER INTEGRATIONS

Type	STR1	STR2	STR3	STR4
Price (incl. VAT)				



AVAILABLE COLOURS



SKIMMER POOLS

The popular variant with slim skimmers for a high water level gives the pool an unusual design. Equipped with a staircase of your choice, it offers optimal comfort and sets a special accent.



Aluminum frame optionally available.

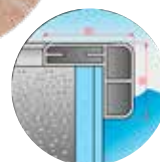

Control your pool from the palm of your hand with the NorsupOne control unit. Go to page 58!

SKIMMER POOLS

Length m	6,00	7,0	8,00	9,80
Width m	3,00	3,50	3,50	3,50
Depth m	1,50	1,50	1,50	1,50
Vol. MAX m ³	27	37	42	51
Price (incl. VAT)				

Excl. transportation costs, labour costs, installation materials and other equipment like lights and skimmers.



Other sizes available on request.



“*The linear design harmonises perfectly with distinctive architecture. Classic and still modern.*”

INFINITY POOLS

The infinity pool ensures infinite pool enjoyment. The overflow grill does not only offer limitless design, but also optimal circulation of the pool water. The water is drained into an expansion tank via the pool edge and pumped through the filter system.

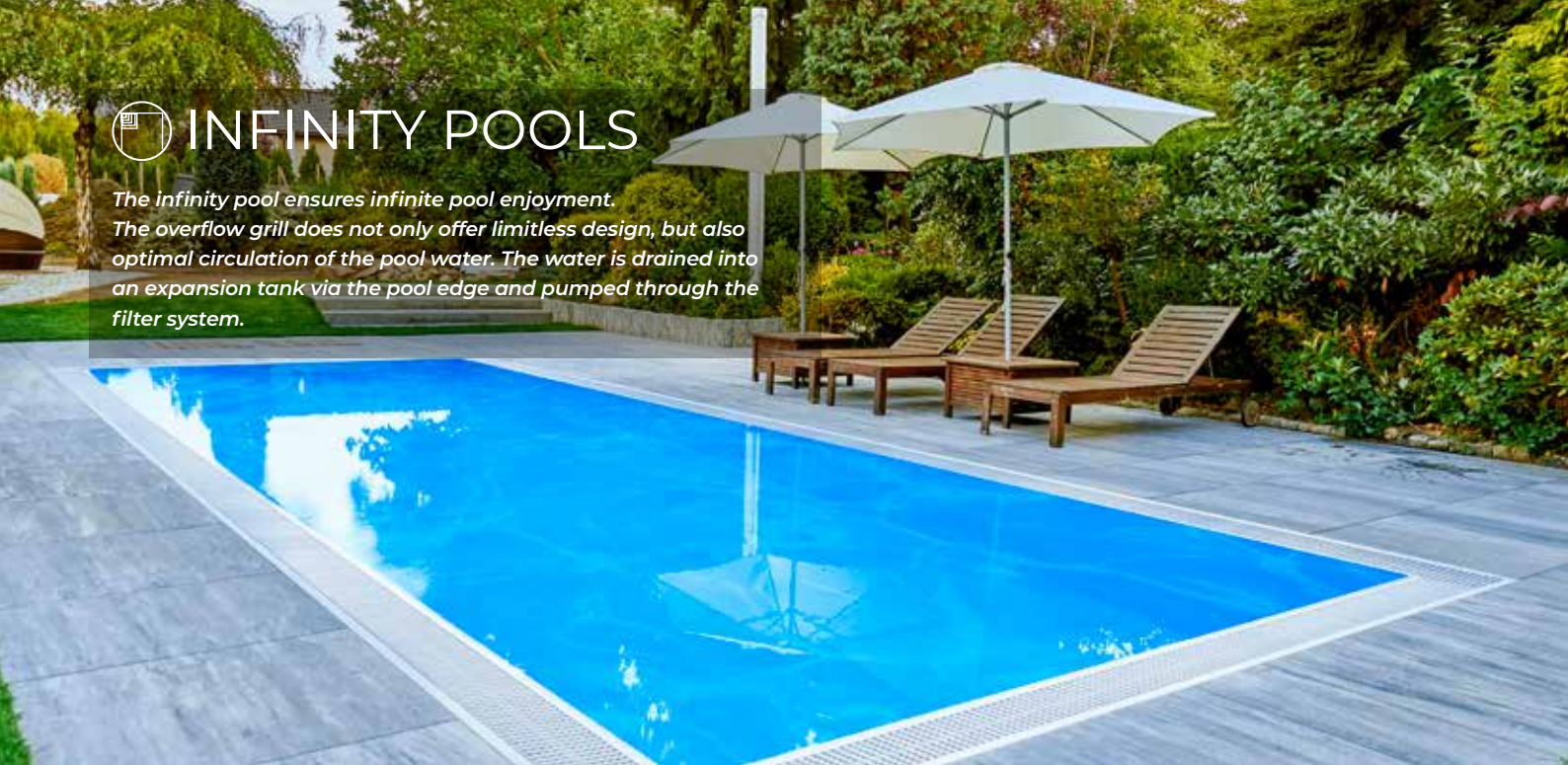

Overflow grill 195 x 35 mm, available in white or silver.

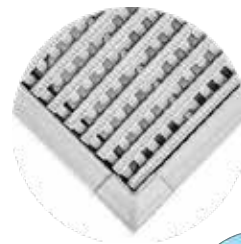

Aluminum frame optionally available.

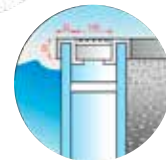

Complete this pool with technical equipment, go to page 36!



INFINITY POOLS

Length m	6,00	7,0	8,00	9,40
Width m	3,00	3,30	3,30	3,30
Depth m	1,50	1,50	1,50	1,50
Vol. MAX m ³	27	35	40	49
Price (incl. VAT)				

Excl. transportation costs, labour costs, installation materials and other equipment like lights and skimmers.



Other sizes available on request.



“

*The maximum water level
conveys the feeling of limitless freedom.
The first choice for infinite
swimming pleasure.*



3.

POOL COVERS

- | | | |
|-----|-----------------|----|
| 3.1 | Pool enclosures | 16 |
| 3.2 | Slatted covers | 26 |

3.1

NORSUP POOL ENCLOSURES

Get the most out of your pool. More efficient, less expensive, and with no need to conform to the weather. Our wide range of shapes and colour options will ensure that the enclosure blends in with your garden. In today's age, pool enclosures are a must-have feature of pools. The current weather conditions being one of the main reasons, the enclosure will prolong the pool bathing season considerably and increase the value of investing in the pool. The pool enclosure is resistant to water, dampness and is low-maintenance.





Our sliding roofs are manufactured individually according to customer requirements.



THE PERFECT POOL FOR EVERY HOME

Thanks to many years of experience and high-quality robust materials, Norsup is able to offer a longlasting system in various designs that meets every requirement. From walk-in to extra flat versions. At the customer's request, all size requirements are customised, and various options available for all pool requirements.

GENERAL FEATURES

- Solid, aluminium profiles
- Extra flat rails made of anodised aluminum (15 mm flat)
- Glass fronts removable on both sides
- High quality castors
- 4 mm thick polycarbonate glazing (crystal clear)
- Rubber seal between the segments
- With rubber sealing lip on both sides
- Optionally also with electric drive

ADVANTAGES OF NORSUP POOL COVERS

Water quality	Prevents water fouling, protects against dust, eaves, and insects
Safety	Prevents children or pets falling into the pool.
Energy saving	Reduces costs of water heating, prevents heat loss.
Season extension	Prolongs the bathing season by several months.

Read more about this in our blogs on www.norsup.eu



SUPREME LINE



PREMIUM LINE



PRO LINE



BASIC LINE



SUPREME LINE

The Supreme Line combines modern design with sophisticated functionality. The flat track on one side allows easy access to the pool. In three different colors, the roofs harmoniously fit in every garden.



SUPREME LINE

FEATURES

- Very flat and angular design
- Single-sided track (15 mm flat)
- Thanks to the integrated tilt joints, the glass fronts can be tilted by approx. 45 ° for ventilation
- Solid, aluminium profiles
- Extra flat rails made of anodized aluminum (15 mm flat)
- Glass fronts removable on both sides
- High quality castors
- 4 mm thick polycarbonate glazing (crystal clear)
- Rubber seal between the segments
- With rubber sealing lip on both sides
- Optionally also with electric drive

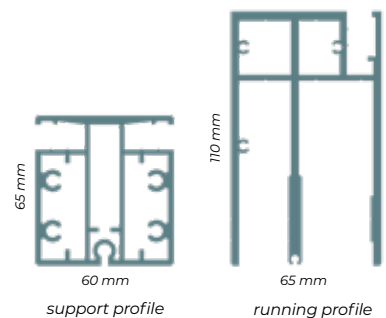
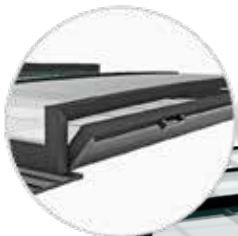

AVAILABLE COLOURS



Anthracite
powder coated
RAL 7016



Silver
aluminum
anodised



White
powder coated
RAL 9016

	LENGTH 550 TO 750 CM	LENGTH 751 TO 850 CM	LENGTH 851 TO 1,000 CM
Total height	No. of segments: 3 width tracks: 27.7 cm	No. of segments: 4 width tracks: 27.2 cm	No. of segments: 4 width tracks: 37.2 cm
Inside width 350 cm	47 cm	57 cm	57 cm
Inside width 400 cm	48 cm	58 cm	58 cm
Inside width 450 cm	49 cm	59 cm	59 cm
Inside width 500 cm	50 cm	60 cm	60 cm
	Price (incl. VAT)	Price (incl. VAT)	Price (incl. VAT)
Inside width 350 cm			
Inside width 400 cm			
Inside width 450 cm			
Inside width 500 cm			
Lengthening of tracks per metre			
On-site assembly			

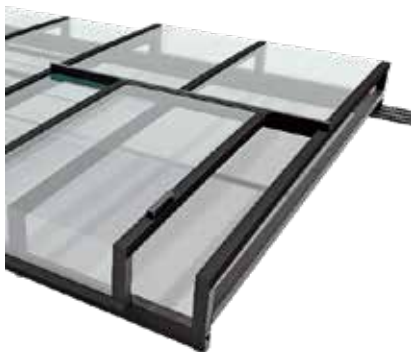

	Price (incl. VAT)
Side sliding door	

Only possible for the largest segment.

	Price (incl. VAT)
Door lock	



	Price (incl. VAT)
Lockable locking bolt	

	Price (incl. VAT)
Electric drive with remote control	





PREMIUM LINE

The Premium Line is both subtle & classic in its design. The flat tracks on both sides are inconspicuous and guarantee easy opening and closing of the roof.



PREMIUM LINE

FEATURES

- Square design with a slightly arched roof
- Running rails on both sides (15 mm flat)
- High quality plastic rolls
- Glass fronts removable on both sides
- High quality castors
- 4 mm thick polycarbonate glazing (crystal clear)
- Rubber seal between the segments
- With rubber sealing lip on both sides
- Optionally also with electric drive

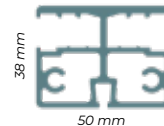

support profile



running profile

AVAILABLE COLOURS



Anthracite
powder coated
RAL 7016

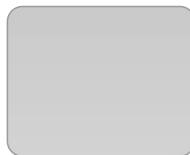

Silver
aluminum
anodised

	LENGTH 550 TO 750 CM	LENGTH 751 TO 850 CM	LENGTH 851 TO 1,000 CM
Total height	No. of segments: 3 width tracks: 21.6 cm	No. of segments: 4 width tracks: 28.6 cm	No. of segments: 4 width tracks: 28.6 cm
Inside width 350 cm	60 cm	65 cm	65 cm
Inside width 400 cm	65 cm	70 cm	70 cm
Inside width 450 cm	70 cm	75 cm	75 cm
Inside width 500 cm	75 cm	80 cm	80 cm
	Price (incl. VAT)	Price (incl. VAT)	Price (incl. VAT)
Inside width 350 cm			
Inside width 400 cm			
Inside width 450 cm			
Inside width 500 cm			
Lengthening of tracks per metre			
On-site assembly			



	Price (incl. VAT)
Side sliding door	

Only possible for the largest segment.

	Price (incl. VAT)
Ventilation flap	



	Price (incl. VAT)
Door lock	

	Price (incl. VAT)
Lockable locking bolt	



	Price (incl. VAT)
Electric drive with remote control	



PRO LINE

The Pro Line offers the most space with a height of up to 1.90 m. Thanks to the universal structure of the roof and the optional revolving door, it is also ideal for pools with access in the middle.



PRO LINE

FEATURES

- Spacious and universal design
- Running rails on both sides (15 mm flat)
- High quality plastic rolls
- Glass fronts removable on both sides
- High quality castors
- 4 mm thick polycarbonate glazing (crystal clear)
- Rubber seal between the segments
- With rubber sealing lip on both sides
- Optionally also with electric drive

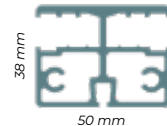

support profile



running profile

AVAILABLE COLORS



Anthracite
powder coated
RAL 7016



Silver
aluminum
anodised

	LENGTH 550 TO 750 CM	LENGTH 751 TO 850 CM	LENGTH 851 TO 1,000 CM
Total height	No. of segments: 3 width tracks: 21.6 cm	No. of segments: 4 width tracks: 28.6 cm	No. of segments: 4 width tracks: 28.6 cm
Inside width 350 cm	130 cm	140 cm	140 cm
Inside width 400 cm	140 cm	150 cm	150 cm
Inside width 450 cm	155 cm	165 cm	165 cm
Inside width 500 cm	165 cm	175 cm	175 cm
	Price (incl. VAT)	Price (incl. VAT)	Price (incl. VAT)
Inside width 350 cm			
Inside width 400 cm			
Inside width 450 cm			
Inside width 500 cm			
Lengthening of tracks per metre			
On-site assembly			



	Price (incl. VAT)
Sliding/revolving door	

Revolving door not possible in connection with ventilation flap; Sliding door only possible for the largest segment.

	Price (incl. VAT)
Ventilation flap	

Revolving door not possible in connection with ventilation flap.



	Price (incl. VAT)
Door lock	

	Price (incl. VAT)
Lockable locking bolt	



	Price (incl. VAT)
Electric drive with remote control	

BASIC LINE

The Basic Line is a classic and medium-high canopy, which is universally suited for every pool. It offers all the advantages of a pool roof at a competitive price.



BASIC LINE

FEATURES

- Classic curved design
- Running rails on both sides (15 mm flat)
- High quality plastic rolls
- Glass fronts removable on both sides
- High quality castors
- 4 mm thick polycarbonate glazing (crystal clear)
- Rubber seal between the segments
- With rubber sealing lip on both sides
- Optionally also with electric drive

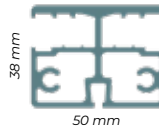

support profile



running profile

AVAILABLE COLORS



Anthracite
powder coated
RAL 7016



Silver
aluminum
anodised

	LENGTH 550 TO 750 CM	LENGTH 751 TO 850 CM	LENGTH 851 TO 1,000 CM
Total height	No. of segments: 3 width tracks: 21.6 cm	No. of segments: 4 width tracks: 28.6 cm	No. of segments: 4 width tracks: 28.6 cm
Inside width 350 cm	80 cm	90 cm	90 cm
Inside width 400 cm	85 cm	95 cm	95 cm
Inside width 450 cm	90 cm	100 cm	100 cm
Inside width 500 cm	95 cm	100 cm	100 cm
	Price (incl. VAT)	Price (incl. VAT)	Price (incl. VAT)
Inside width 350 cm			
Inside width 400 cm			
Inside width 450 cm			
Inside width 500 cm			
Lengthening of tracks per metre			
On-site assembly			



	Price (incl. VAT)
Side sliding door	

Only possible for the largest segment.

	Price (incl. VAT)
Ventilation flap	



	Price (incl. VAT)
Door lock	

	Price (incl. VAT)
Lockable locking bolt	



	Price (incl. VAT)
Electric drive with remote control	

3.2

NORSUP SLAT COVER

Norsup Polycarbonate solar slatted cover comes with UV protection in the base material. Its surface layer prevents aging of the slat material. Optimal solar effect slats used with transparent surface and black under layer for maximum heat gain. It has a perfect geometry which makes the profile stable and extremely weather resistant (severe hailstorms). Double hook connection ensures a secure cover that can be rolled up on two sides. The opening in the end cap helps the slat clean itself by allowing water to flow through the hook connection to reduce algae growth.



FEATURES

- Optimal polycarbonate Solar slats
- UV protection in the base material
- Surface layer prevents material aging
- Easy removal of individual slats
- Stable & highly weather resistant (up to 5cm hail resistant)
- Double hook connection
- Open structure of the end slat to prevent algae growth
- Different packaging options for easy transportation

AVAILABLE COLOURS

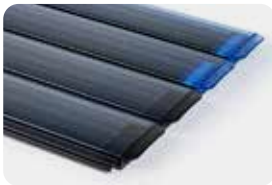

Solar blue



Solar silver



Solar transparent

Exclusive offer available of solar slats but other non-solar options available.



NORSUP SLAT POOL COVER DRIVE SYSTEM

With decades of manufacturing experience and expertise, Norsup is offering high-quality pool cover drive systems. The Norsup pool drive system is suitable for all swimming pools: Concrete/liner; Prefab and EPS blocks. Both pool drive systems and mounting sets are made of stainless steel 316-L (1.4404) with POM-C bearings. Our pool drive systems are equipped with motors with a capacity of 250Nm or 450Nm. A motor with 600Nm is available on request.



NORSUP 3 YEARS WARRANTY

Please contact our sales team for the different sizes and options

NORSUP TELESCOPIC POOL DRIVE SYSTEM

- It is a "one size fits for all" model!
- Fits all pools with width up to 6200mm
- The length of the system is adjustable in size
 - 3000/4000mm, 3850/5200 mm and 5000/6200mm
- Includes 250Nm tube motor, remote control and 25 metre cable
- 30mm axle equipped with POM-C bearings

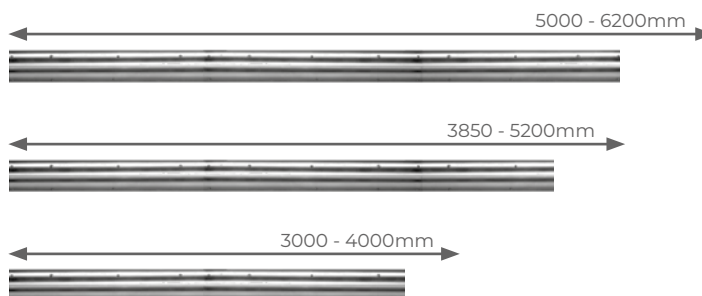

NORSUP POOL DRIVE SYSTEM WITH 250NM MOTOR

- Fits pools with width < 6000mm
- Available with 3 different cable length: 10metre, 20metre, 25metre
- Complete with remote control

NORSUP POOL DRIVE SYSTEM WITH 450NM MOTOR

- Fits pools with width < 6000mm
- Available with 3 different cable length: 10metre, 20metre, 25metre
- Complete with remote control



mounting set for 250Nm motor



control box for 250Nm motor



mounting set for 450Nm motor



control box for 450Nm motor



A full-page background image showing a woman swimming underwater in a pool. She is looking towards the camera with her arms outstretched. The water is clear and blue, with light filtering through from above, creating a shimmering effect. A dark semi-transparent box is overlaid on the lower half of the image, containing the table of contents.

4.

NORSUP TECHNICAL EQUIPMENT

4.1	Norsup pool plant tanks & water splash tanks	30
4.2	Norsup filters	32
4.3	Norsup pumps	38
4.4	Norsup heating	40
4.5	Norsup water treatment	48
4.6	Norsup controlling	50
4.7	Norsup cleaning	52
4.8	Norsup maintenance accessories	54

4.1

NORSUP POOL PLANT TANKS & WATER SPLASH TANKS

Thanks to many years of experience in plant construction with polypropylene materials, we are able to offer a diverse selection of solid PP containers, which are excellent as technology shafts or as a surge water container for overflow basins. With a Norsup technology shaft, your swimming pool technology is always tidy and safely stowed.



POOL PLANT TANKS

Pool plant tanks are embedded in the ground adjacent to your pool. This offers an optimal connection to the pool and ensures secure accommodation of the swimming pool technology. Consisting of polypropylene, the shafts are designed to be very stable and durable. Installed in the floor, they are easily and conveniently accessible via the integrated lid.

FEATURES

- 10 years of warranty on construction
- Stable construction thanks to vertical struts
- High quality polypropylene construction
- With easily accessible lid (min. 80 x 80 cm)
- Can be sunk in the ground
- Also suitable as splash water tank for overflow basins

SMALL TANKS



Type	3SCHA051	3SCHA070	3SCHA020
Size (LxBxH) cm	150 x 120	135 x 70 x 90	150 x 100 x 120
Price (incl. VAT)			
Transportation costs			

LARGE TANKS



Type	3SCHA042	3SCHA030	3SCHA060
Size (LxBxH) cm	150 x 150 x 130	200 x 150 x 130	300 x 200 x 150
Price (incl. VAT)			
Transportation costs			

4.2



NORSUP FILTERS



NORSUP SAND FILTER SUPRA

The Norsup sand filter type Supra is made of fibreglass reinforced polyester. The filter has a weatherproof gel coat layer. Thanks to the large 400mm opening at the top, sand change is an easy job. Because of the transparent cover you can see how polluted the filter bed is.

NORSUP 3 YEARS WARRANTY
 10 YEARS ON TANK
 5 YEARS ON VALVE

FEATURES

- Fibreglass reinforced polyester
- UV resistant
- Large service opening with 400mm cover for easy sand change
- Ideal for all common sizes of private pools
- Praher 6-way valve included
- With air vent plug and drain plug

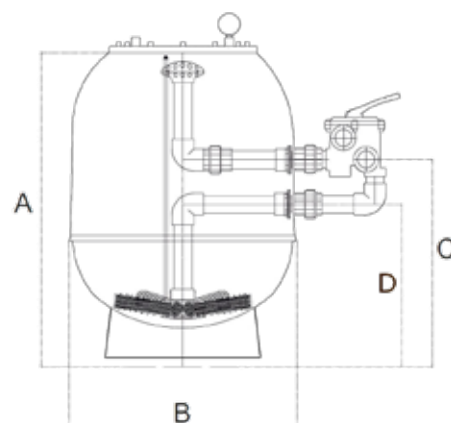

Connection	Glue socket & female thread
Material	Fibreglass reinforced polyester
Pressure	3 bar
Max. temp.	40°C

TYPE SUPRA

Part no.	Type	Diameter (mm)	Connection	Max. Pool Vol. (m ³)	Price (incl. VAT)
7025537	Supra 500	555	50mm / 1 1/2"	60	
7025538	Supra 600	675	50mm / 1 1/2"	90	
7025539	Supra 750	795	63mm / 2"	130	

Part no.	A (mm)	B (mm)	C (mm)	D (mm)	Weight (kg)	Max. flow (m ³ /h)	Sand (kg)
7025537	730	555	433	308	35.5	12	100
7025538	913	675	509	384	48.5	16	150
7025539	1090	795	739	509	67	22	250



NORSUP SAND FILTER DUPLIX

The 2pcs style Norsup Duplex sand filter is ideal for all common larger sized private pools. The upper half of the filter can be completely removed which makes it extremely easy to change sand. With 40 years of manufacture experience, the Norsup Duplex filter offers you absolute premium quality.

NORSUP 3 YEARS WARRANTY
10 YEARS ON TANK
5 YEARS ON VALVE

FEATURES

- High quality fibreglass reinforced polypropylene filter tank and stainless steel ring
- Praher 6-way valve included
- Ideal for all common sizes of private pools
- UV resistant
- With air vent plug and drain plug

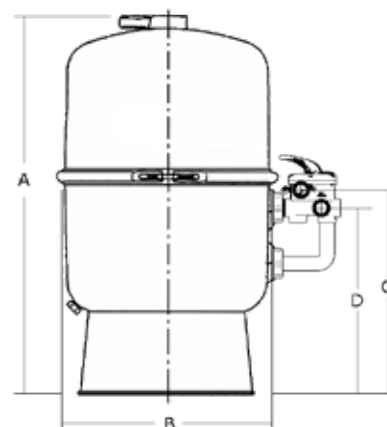

Connection	Glue socket & female thread
Material	Fibreglass reinforced polypropylene
Pressure	1.8 bar
Max. temp.	40 °C

TYPE DUPLIX

Part no.	Type	Diameter (mm)	Connection	Max. Pool Vol. (m ³)	Price (incl. VAT)
7025339	Duplex 400	440	50mm / 1½"	50	
7025340	Duplex 500	547	50mm / 1 ½"	70	
7025341	Duplex 600	652	63mm / 2"	90	

Part no.	A (mm)	B (mm)	C (mm)	D (mm)	Weight (kg)	Max. flow (m ³ /h)	Sand (kg)
7025339	754	440	366	264	11,2	8	50
7025340	825	547	402	300	14,4	12	90
7025341	1022	652	474	372	20,6	16	120



NORSUP SAND FILTER TYPE S

FEATURES

- High quality gel coated filter tank
- Extremely high maximum working pressure up to 3.75 bar
- Praher 6-way valve included

Connection	Female thread
Material	100% PP
Pressure	3.75 bar
Max. temp.	43 °C

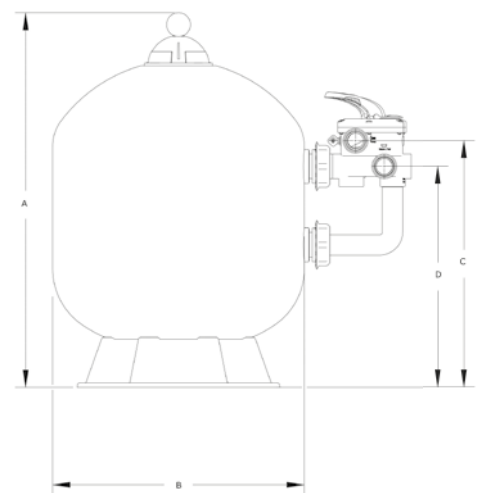

NORSUP **3 YEARS WARRANTY**
 10 YEARS ON TANK
 5 YEARS ON VALVE

TYPE S

Part No.	Type	Diameter (mm)	Connection	Max pool vol. (m ³)	Price (incl. VAT)
7024551	S450	450	1 1/2"	30	
7024553	S530	530	1 1/2"	50	
7024555	S620	620	1 1/2"	70	
7024557	S790	790	2"	110	

Part No.	A (mm)	B (mm)	B (inch)	C (mm)	D (mm)	Weight (kg)	Max. flow (m ³ /h)	Sand (kg)
7024551	645	450	18	416	356	9.0	6.0	75
7024553	795	530	21	491	431	12.0	10.0	100
7024555	830	620	25	509	449	14.0	14.0	150
7024557	1010	790	31	630	570	27.0	22.0	250



NORSUP SAND FILTER TYPE T

FEATURES

- High quality gel coated filter tank
- Extremely high maximum working pressure up to 3.75 bar
- Praher 6-way valve included

Connection	Metric/imperial glue socket
Material	100% PP
Pressure	3.75 bar
Max. temp.	43 °C

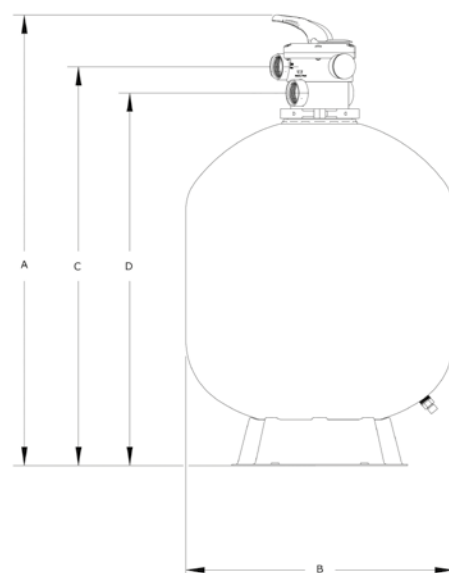

TYPE T

Part No.	Type	Diameter (mm)	Connection	Max pool vol. (m ³)	Price (incl. VAT)
7024559	T450	450	50 / 1½	30	
7024561	T530	530	50 / 1½	50	
7024563	T620	620	50 / 1½	70	

Part No.	A (mm)	B (mm)	B (inch)	C (mm)	D (mm)	Weight (kg)	Max. flow (m ³ /h)	Sand (kg)
7024559	770	450	18	660	600	9.0	6.0	75
7024561	926	530	21	816	756	12.0	10.0	100
7024563	962	620	25	852	792	14.0	14.0	150

NORSUP 3 YEARS WARRANTY

10 YEARS ON TANK
5 YEARS ON VALVE



NORSUP FILTER SET TYPE SUPRA

NORSUP 3 YEARS WARRANTY
 10 YEARS ON TANK
 5 YEARS ON VALVE

Norsup filter set type Supra consists of Supra sand filter and EVO+ pool pump. It provides the perfect combination for optimal filtration of all popular sizes of private pools. The set consists of filters with 6-way valve, circulation pump and pallet tray. Components are supplied individually and can be easily mounted and cased. This offers the advantage of easy positioning in the plant room.

FEATURES

- Ideal for all common sizes of private pools
- Including filter pallet
- Large service opening with 400mm cover for easy sand change
- Saltwater suitable up to 0.4% (4gr/ltr)
- Optimum filter performance
- Praher 6-way valve included
- 10 years tank warranty + 5 years valve warranty



Connection	Glue socket & female thread
Material	Fibreglass
Pressure	3 bar
Max. temp.	40 °C

TYPE SUPRA & EVO+

Part no.	Type	Diameter (mm)	Flow (m ³ /h)	Max. Pool Vol. (m ³)	Price (incl. VAT)
7027153	Supra 500 EVO+11 with bottom plate	555	11	50	
7027154	Supra 500 EVO+13 with bottom plate	555	13	60	
7027155	Supra 600 EVO+13 with bottom plate	675	13	70	
7027156	Supra 600 EVO+15 with bottom plate	675	15	80	
7027157	Supra 750 EVO+15 with bottom plate	795	15	100	
7027158	Supra 600 EVO+VSTD with bottom plate	675	24	90	
7027159	Supra 750 EVO+VSTD with bottom plate	795	24	130	

NORSUP FILTER SET TYPE DUPLEX

NORSUP 3 YEARS WARRANTY
10 YEARS ON TANK
5 YEARS ON VALVE

Norsup filter set type Duplex consists of duplex sand filter and EVO+ pool pump. It provides the perfect combination for optimal filtration of all popular sizes of private pools. The set consists of filters with 6-way valve, circulation pump and pallet tray. Components are supplied individually and can be easily mounted and cased. This offers the advantage of easy positioning in the plant room.

FEATURES

- Ideal for all common sizes of private pools
- Including filter pallet
- Two-part filter body for easy sand changes
- Saltwater suitable up to 0,4% (4gr/ltr)
- Optimum filter performance
- Praher 6-way valve included
- 10 years tank warranty + 5 years valve warranty



Connection	Glue socket & female thread
Material	Fibreglass
Pressure	1.8 bar
Max. temp.	40 °C

TYPE DUPLEX & EVO+

Part no.	Type	Diameter (mm)	Flow (m ³ /h)	Max. Pool Vol. (m ³)	Price (incl. VAT)
7027147	Duplex 400 EVO+7 with bottom plate	440	7	40	
7027148	Duplex 500 EVO+11 with bottom plate	547	11	60	
7027149	Duplex 500 EVO+13 with bottom plate	547	13	70	
7027150	Duplex 600 EVO+13 with bottom plate	652	13	80	
7027151	Duplex 600 EVO+15 with bottom plate	652	15	90	
7027152	Duplex 600 EVO+VSTD with bottom plate	652	24	90	

BOTTOM PALLET FOR FILTERSETS

The Norsup pool pumps work together perfectly with the Norsup filters. With this bottom pallet you can make a set out of it. Select a filter and pump and we can advise you on the bottom pallet size. All parts are delivered separately and need still to be connected.



Part no.	Size
7025342	630 x 420mm
7025343	750 x 500mm
7025344	1000 x 550mm



NORSUP POOL PUMP TYPE EVO+ VSTD

NORSUP 4 YEARS WARRANTY

Equipped with an integrated control, this pump can be individually programmed to your customer's needs. With the timer function it is possible to set up to five different speeds at specific times. In addition, the pump has a skimmer function, which allows an interval to be programmed so that the pump runs at a high speed for a short time (for example, every three hours for five minutes at 3000 rpm) to agitate the water surface and improve filtration. Operation with an external swimming pool control via the integrated control cable is also possible. Due to the variable speed, the pump can operate very quietly. The pump can be installed on existing connections to pumps of the following models: Badu Bettar, Badu Top II, Badu 90, Badu Magna, Badu Prime etc.

FEATURES

- Timer with 5 daily speed changes possible
- Skimmer function for clean water surface
- Control cable for external controls
- Up to 24 m³ (at 8m H [m])
- Connections: 1.5 "/ 2" female thread
- Saltwater resistant: up to 0.4% (4 g / l)
- Insulation: class F
- Protection: IP55
- Motor shaft: stainless steel 316
- German high specification motor
- Motor with thermal protection



Made in Germany



RECOMMENDED CONNECTION

50 mm x 1.5 "Art-Nr: 0100432
63 mm x 2 "Art-Nr: 0100433

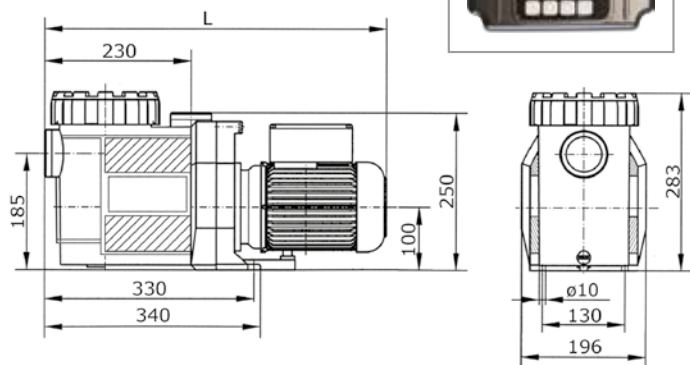
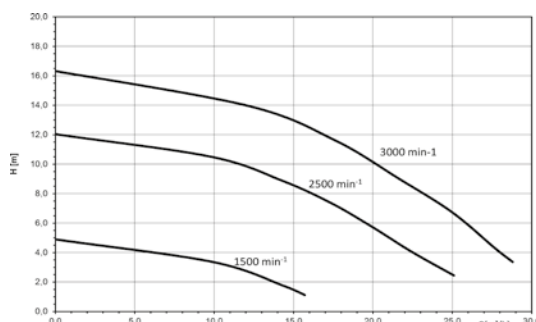

Part No.	Type	Motor power (kW)	Voltage	Size	Price (incl. VAT)
7025266	EVO+ VSTD	1,10	230 V	2" x 1 1/2"	



NORSUP POOL PUMP TYPE EVO+

NORSUP 4 YEARS WARRANTY

Pool pump with perfect hydraulic features and high-end finish. Quiet and reliable German quality motor. High quality glass fibre reinforced materials used to create a timeless design. Because of the universal pump design, the pump can also be integrated in existing installations of well known brands.

FEATURES

- Connection: 1.5" / 2" female thread
- Transparent cover
- Saltwater suitable up to 0.4% (4gr/ltr)
- Insulation: Class F
- Protection: IP55
- Motor shaft: stainless steel 316
- German high specification motor
- Motor with thermal protection

RECOMMENDED CONNECTION

50 mm x 1.5 "Art-Nr: 0100432
63 mm x 2 "Art-Nr: 0100433



Made in Germany

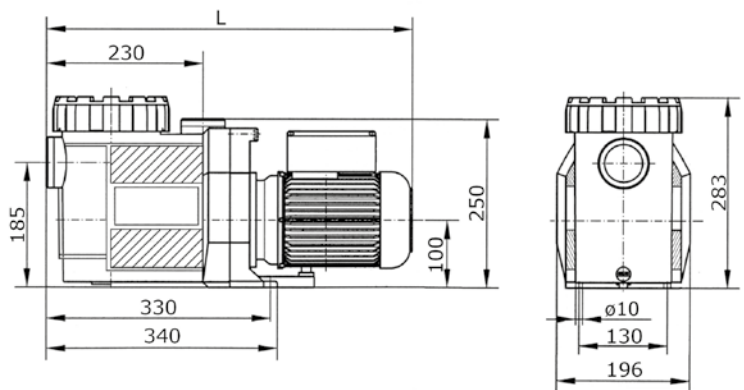
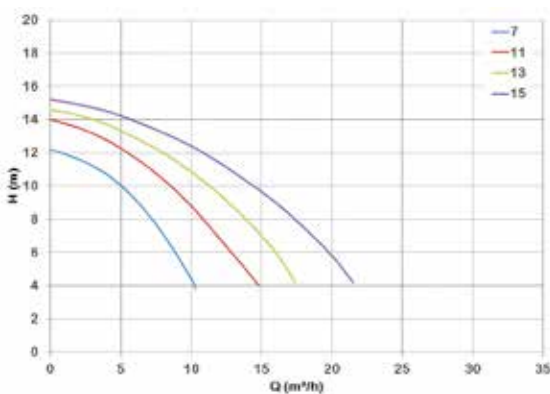

Part No.	Type	Motor power (kW)	Output power (HP)	Voltage	Size	Weight (kg)	Price (incl. VAT)
7024565	EVO+ 7	0.30	0.4	230VAC	1 1/2"	9.2	
7024566	EVO+ 11	0.45	0.6	230VAC	1 1/2"	9.5	
7024567	EVO+ 13	0.55	0.75	230VAC	2" x 1 1/2"	11.0	
7024568	EVO+ 15	0.75	1	230VAC	2" x 1 1/2"	13.0	

4.4



NORSUP HEATING



NORSUP HEAT PUMP INVERTER PX

HORIZONTAL

The Norsup full inverter heat pump makes it possible to adjust the speed of the ventilator from 10% to 100%, depending on the outside temperature and water temperature. This significantly reduces energy consumption and noise levels. The Norsup heat pump reaches the desired temperature fast and reduces temperature fluctuations. Efficient, ecological and economical. Furthermore, the heat pump is equipped with a 5 inch high-end touch screen display with which you can set temperatures and programs. It also provides you with the consumption and temperature history.

And with the especially developed app, you can remotely control the heat pump from smartphone or tablet.

The heatpump uses R32 refrigerant instead of R410A. Both refrigerants are energy efficient and green, but the R32 refrigerant has a 3 times lower GWP (Global Warming Potential) than the R410A.

TYPE PX HORIZONTAL

Part no.	Type	Heating capacity A27/W27	Cop A27/W27	Heating capacity A15/W25	Cop A15/W25	Pool Volume (m ³)*	Price (incl. VAT)
7024626	P13X/32	13-3.0	16-6.7	9.2-2.0	8-5.2	35-60	
7024627	P17X/32	17-3.8	16-6.7	11.5-3.0	8.2-5.2	45-80	
7024628	P20X/32	20-4.6	16-6.7	14-3.0	8.2-5.1	55-95	
7024629	P20TX/32	19.5-4.6	12.43-5.5	14-3.0	8.2-5.1	55-95	
7024630	P26X/32	26-6.8	16-6.7	19-5.4	8.2-5.2	75-130	
7024631	P26TX/32	26-6.8	16-6.7	19-5.4	8.2-5.2	75-130	
7024740	P35X/32	35.0-8	16-6.7	24-5.6	8.2-5.2	100-175	
7024632	P35TX/32	35.0-8	16-6.7	24-5.6	8.2-5.2	100-175	

*Provided it is correctly insulated, calculation model: max vol 7x heating capacity (A15/W25) / min vol 4x heating capacity (A15/W25). Winter cover included.



Including 5 inch full color display and app for remote control with smartphone or tablet.



FEATURES

- Energy label: A
- COP up to 16
- The heat pump inverter provides the opportunity to automatically adjust heating capacities to suit weather conditions
- “All seasons” model works down to -15°C
- Cabinet made of ABS
- Full flow
- Easy digital temperature control with LCD display and remote control with SmartControl app
- Quiet running with silent rotary compressor and variable speed fan
- All functions are microprocessor controlled
- Soft start, no voltage peaks
- R32 gas for environmentally friendly operation
- Automatic defrost
- Titanium heat exchanger resistant to salt and chlorine
- Drain and flow switch
- Winter cover included



NORSUP 4 YEARS WARRANTY
 10 YEARS ON COMPRESSOR
 10 YEARS ON HEAT EXCHANGER

ENERGY Swimming Pool Heat Pump

COP

A B C D

A



TYPE PX HORIZONTAL TECHNICAL DATA

		MODEL P13X/32	MODEL P17X/32	MODEL P20X/32	MODEL P20TX/32
Part no.		7024626	7024627	7024628	7024629
Heating Capacity A27/W27 (max.-min.)	KW	13-3.0	17-3.8	20-4.6	4.6-19.5
Heating Capacity A15/W25 (max.-min.)	KtW	9.2-2.0	11.5-3.0	14-3.0	14-3.0
Power input (max.-min.)	KW	1.94-0.19	2.54-0.24	2.98-0.29	0.37~3.54
Swimming pool volume*	m ³	35-60	45-80	55-95	55-95
Rated current	A	9,7	17,2	20,6	6,9
Minimum fuse	A	14,5	25,8	30,9	10,3
COP at A27/W27		16-6.7	16-6.7	16-6.7	12.43~5.5
COP at A15/W25		8-5.2	8.2-5.2	8.2-5.1	8.2-5.1
Power Supply	V/Ph/Hz	220~240/1/50	220~240/1/50	220~240/1/50	380/3/50
Heat exchanger		Twist-titanium tube in PVC	Twist-titanium tube in PVC	Twist-titanium tube in PVC	Twist-titanium tube in PVC
Condenser		Titanium	Titanium	Titanium	Titanium
Compressor type		Rotary	Rotary	Rotary	Rotary
Compressor brand		Hitachi	Hitachi	Mitsubishi	Mitsubishi
Refrigerant		R32	R32	R32	R32
Fan Quantity		1	1	1	1
Fan Direction		Horizontal	Horizontal	Horizontal	Horizontal
Fan Rotate Speed	RPM	400-800	500-750	500-900	500-900
Noise - Silence mode (10m)	dB(A)	22	24	25	25
Water Connection	mm	50	50	50	50
Nominal Flow Volume	m ³ /h	4,2	5,3	6,6	6,6
CO ₂ equivalent	TON	0.47ton	0.44ton	0.68ton	0.68ton
Net Dimensions L/W/H	MM	1045x450x770	1165x485x870	1165x485x870	1165x485x870
Shipping Dimensions L/W/H	MM	1130x460x780	1210x510x880	1210x510x880	1210x510x880
Wifi module		include	include	include	include

*Provided it is correctly insulated, calculation model: max vol 7x heating capacity (A15/W25) / min vol 4x heating capacity (A15/W25). Winter cover included.

		MODEL P26X/32	MODEL P26TX/32	MODEL P35X/32	MODEL P35TX/32
Part no.		7024630	7024631	7024740	7024632
Heating Capacity A27/W27 (max.-min.)	KW	26-6.8	26-6.8	35.0-8	35.0-8
Heating Capacity A15/W25 (max.-min.)	KW	19-5.4	19-5.4	24-5.6	24-5.6
Power input (max.-min.)	KW	3.88-0.43	3.88-0.43	5.2-0.5	5.2-0.5
Swimming pool volume*	m ³	75-130	75-130	100-175	100-175
Rated current	A	24	9,5	30	10
Minimum fuse	A	36	14,25	45	15
COP at A27/W27		16-6.7	16-6.7	16-6.7	16-6.7
COP at A15/W25		8.2-5.2	8.2-5.2	8.2-5.2	8.2-5.2
Power Supply	V/Ph/Hz	220~240/1/50	380/3/50	220~240/1/50	380/3/50
Heat exchanger		Twist-titanium tube in PVC	Twist-titanium tube in PVC	Twist-titanium tube in PVC	Twist-titanium tube in PVC
Condenser		Titanium	Titanium	Titanium	Titanium
Compressor type		Rotary	Rotary	Rotary	Rotary
Compressor brand		Mitsubishi	Mitsubishi	Mitsubishi	Mitsubishi
Refrigerant		R32	R32	R32	R32
Fan Quantity		2	2	2	2
Fan Direction		Horizontal	Horizontal	Horizontal	Horizontal
Fan Rotate Speed	RPM	400-800	400-800	400-900	400-900
Noise - Silence mode (10m)	dB(A)	26	26	28	28
Water Connection	mm	50	50	50	50
Nominal Flow Volume	m ³ /h	8,6	8,6	10,0	10,0
CO ₂ equivalent	TON	0.88ton	0.88ton	0.88ton	0.88ton
Net Dimensions L/W/H	MM	1165x470x1275	1165x470x1275	1165x470x1275	1165x470x1275
Shipping Dimensions L/W/H	MM	1210x495x1300	1210x495x1300	1210x495x1300	1210x495x1300
Wifi module		include	include	include	include

*Provided it is correctly insulated, calculation model: max vol 7x heating capacity (A15/W25) / min vol 4x heating capacity (A15/W25). Winter cover included.





NORSUP HEAT PUMP INVERTER PV

VERTICAL

The full inverter heat pump offers the ability to vary the heating capacity to suit weather conditions. Low noise rotary compressor and low noise variable speed fan motor reduce ambient noise and energy consumption. The vertical fan on this unit is ideal to allow installation in confined areas. Wi-Fi module is also included in the package.

TYPE PV VERTIKAL

Part no.	Type	Heating capacity A27/W27	Cop A27/W27	Heating capacity A15/W25	Cop A15/W25	Pool volume (m ³)	Price (incl. VAT)
7026965	P13V/32	13.5 - 3.7	13.4 - 7	10 - 2.7	6.2 - 5	35-60	
7026966	P17V/32	17.0 - 3.4	13 - 6.6	12.7 - 2.7	6.8 - 5	45-80	
7026967	P21V/32	21.3 - 6.2	15.6 - 7.3	16.3 - 6.5	7 - 5.4	60-110	
7026968	P21TV/32	21.1 - 6.3	14.8 - 7.6	16.3 - 4.5	7.4 - 5.6	60-110	
7026969	P24V/32	24.9 - 5.6	15.2 - 6.4	18.7 - 4.4	7.1 - 5.1	70-125	
7026970	P24TV/32	24.3 - 5.5	14.2 - 6.6	18.8 - 4.1	7.1 - 5.1	70-125	
7026971	P31V/32	30.6 - 8.5	14.3 - 6.3	23.8 - 6.4	7.8 - 5	90-160	
7026972	P31TV/32	31.2 - 8.8	15.7 - 6.1	23.6 - 6.5	8.2 - 5	90-160	
7026973	P35V/32	35.0 - 7.1	11.4 - 5.1	27.5 - 6.4	6.5 - 4.1	105-185	
7026974	P35TV/32	35.5 - 7.8	12.2 - 5.2	27.5 - 6.4	6.8 - 4.1	105-185	



4 YEARS WARRANTY
 10 YEARS ON COMPRESSOR
 10 YEARS ON HEAT EXCHANGER

FEATURES

- Energy label A
- Full colour touch screen
- Automatically adjusts heating capacity to suit weather conditions
- “All season” model works until -15°C
- Quiet running with low noise rotary compressor and low noise
- Variable speed fan motor
- Reduce energy consumption by using power/smart/silent modes
- Automatic heating and cooling
- Automatic defrost
- Efficient COP up to 16
- Cabinet made of ABS
- Titanium twisted heat exchanger resist to salt and chlorine
- Soft start, no voltage peaks
- R32 gas, which has a 3x lower GWP (Global Warming Potential) than the R410A
- 4 years warranty for heat pump, 10 years warranty for compressor and heat exchanger
- Winter cover included
- Maximum pool volume depending on environmental conditions

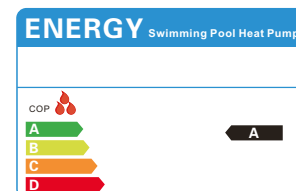

Including 5 inch full colour display and app for remote control with smartphone or tablet.

Integrated WiFi connection



TYPE PV VERTICAL TECHNICAL DATA

TYPE PV VERTICAL		MODEL P12V/32	MODEL P17V/32	MODEL P21V/32	MODEL P21TV/32	MODEL P24V/32
Part no.		7026965	7026966	7026967	7026968	7026969
Heating capacity A27/W27 (max. - min.)	kW	13.5-3.7	17-3.4	21.3-6.2	21.1-6.3	24.9-5.6
Heating capacity A15/W25 (max. - min.)	kW	10-2.7	12.7-2.7	16.3-6.5	16.3-4.5	18.7-4.4
Power input (max.-min.)	kW	2.9-0.23	3.54-0.31	4.55-0.43	5.2-0.43	5.3-0.47
Swimming pool volume*	m ³	35-60	45-80	60-110	60-110	70-125
Rated current	A	12	14.8	17.7	8.7	22.6
Minimum fuse	A	20	20	30	20	30
COP at A27/W27		13.4-7	13-6.6	15.6-7.3	14.8-7.6	15.2-6.4
COP at A15/W25		6.2-5	6.8-5	7-5.4	7.4-5.6	7.1-5.1
Power supply	V/Ph/Hz	220-240/1/50	220-240/1/50	220-240/1/50	380/3/50	220-240/1/50
Evaporator		Hydrophilic finned heat exchanger	Hydrophilic finned heat exchanger	Hydrophilic finned heat exchanger	Hydrophilic finned heat exchanger	Hydrophilic finned heat exchanger
Condenser		Twisted double coil PVC titanium heat exchanger	Twisted double coil PVC titanium heat exchanger	Twisted double coil PVC titanium heat exchanger	Twisted double coil PVC titanium heat exchanger	Twisted double coil PVC titanium heat exchanger
Compressor type		Rotary	Rotary	Rotary	Rotary	Rotary
Compressor brand		Mitsubishi	Mitsubishi	Panasonic	Panasonic	Panasonic
Refrigerant		R32	R32	R32	R32	R32
Fan quantity		1	1	1	1	1
Fan direction		Vertical	Vertical	Vertical	Vertical	Vertical
Fan rotate speed	RPM	500-700	500-700	500-700	500-700	600-750
Noise level (1 m)	dB(A)	44-54	46-56	48-56	48-56	50-56
Noise level (10 m)	dB(A)	24-34	26-36	28-38	28-38	30-40
Noise - silence mode (10 m)	dB(A)	24	26	28	28	30
Water connection	mm	50	50	50	50	50
Nominal flow rate	m ³ /h	4.2	5.5	7.0	7.1	9.0
Gas quantity	kg	0.65	0.8	1.35	1.35	1.65
CO ₂ equivalent	Tonne	0.44	0.54	0.91	0.91	1.05
Net dimensions	mm	723/835/865	723/835/865	770/990/970	770/990/970	770/990/970
Shipping dimensions	mm	773/885/915	773/885/915	820/1040/1000	820/1040/1000	820/1040/1000
Wi-Fi Module		include	include	include	include	include

*Provided it is correctly insulated, calculation model: max vol 7x heating capacity (A15/W25) / min vol 4x heating capacity (A15/W25). Winter cover included.



TYPE PV VERTICAL		MODEL P24TV/32	MODEL P31V/32	MODEL P31TV/32	MODEL P35V/32	MODEL P35TV/32
Part no.		7026970	7026971	7026972	7026973	7026974
Heating capacity A27/W27 (max. - min.)	kW	24.3-5.5	30.6-8.5	31.2-8.8	35.0-7.1	35.5-7.8
Heating capacity A15/W25 (max. - min.)	kW	18.8-4.1	23.8-6.4	23.6-6.5	27.5-6.4	27.5-6.4
Power input (max.-min.)	kW	5.7-0.47	7.0-0.53	7.0-0.55	8.6-0.64	8.95-0.66
Swimming pool volume*	m ³	70-125	90-160	90-160	105-185	105-185
Rated current	A	11.74	23	13.3	32.5	14.4
Minimum fuse	A	20	40	20	40	20
COP at A27/W27		14.2-6.6	14.3-6.3	15.7-6.1	11.4-5.1	12.2-5.2
COP at A15/W25	7.1-5.1	7.8-5	8.2-5	6.5-4.1	6.8-4.1	7.1-5.1
Power supply	V/Ph/Hz	380/3/50	220-240/1/50	380/3/50	220-240/1/50	380/3/50
Evaporator		Hydrophilic inned heat exchanger	Hydrophilic inned heat exchanger	Hydrophilic inned heat exchanger	Hydrophilic inned heat exchanger	Hydrophilic inned heat exchanger
Condenser		Twisted double coil PVC titanium heat exchanger	Twisted double coil PVC titanium heat exchanger	Twisted double coil PVC titanium heat exchanger	Twisted double coil PVC titanium heat exchanger	Twisted double coil PVC titanium heat exchanger
Compressor type		Rotary	Rotary	Rotary	Rotary	Rotary
Compressor brand		Panasonic	Mitsubishi	Mitsubishi	Mitsubishi	Mitsubishi
Refrigerant		R32	R32	R32	R32	R32
Fan quantity		1	1	1	1	1
Fan direction		Vertical	Vertical	Vertical	Vertical	Vertical
Fan rotate speed	RPM	600-750	500-700	500-700	500-750	500-750
Noise level (1 m)	dB(A)	50-56	50-57	50-57	53-59	53-59
Noise level (10 m)	dB(A)	30-40	33-43	33-43	35-45	35-45
Noise - silence mode (10 m)	dB(A)	30	33	33	35	35
Water connection	mm	50	50	50	50	50
Nominal ow rate	m ³ /h	9.0	12.5	12.5	14.6	14.6
Gas quantity	kg	1.65	1.8	1.8	1.9	1.9
CO ₂ equivalent	Tonne	1.05	1.22	1.22	1.28	1.28
Net dimensions	mm	770/990/970	920/960/1025	920/960/1025	920/960/1025	920/960/1025
Shipping dimensions	mm	820/1040/1000	970/1010/1075	970/1010/1075	970/1010/1075	970/1010/1075
Wi-Fi Module		include	include	include	include	include

*Provided it is correctly insulated, calculation model: max vol 7x heating capacity (A15/W25) / min vol 4x heating capacity (A15/W25). Winter cover included.

4.5



NORSUP WATER TREATMENT



NORSUP CHLORINATOR TYPE LOW SALT

Norsup Salt chlorinator is ideal for any private pools up to 100m³. This Low salt chlorinator is easy to install, it includes a high quality cell , pH and ORP probe plug & play kit. A smart, user friendly, LCD interface displays water temp, pH, salt level and chlorine production. Smart Power ® Technology offers stable chlorine production. The system also offer self-cleaning of the cell, a 'Boost' mode for super chlorination and 'Low' mode to adjust chlorine production in accordance with poll cover operation. It is a great combination to use together with the NorsupOne control unit to enjoy wireless control and expanded functionality via the NorsupOne App.

FEATURES

- Great combination with NorsupOne control unit for wireless control and expanded functionality via NorsupOne App
- Salt quantity 1.5g/l , Chlorine production 20g/h
- Glass probe for PH and ORP
- PH regulation adjustable from 6.9 to 7.6
- Self-cell cleaning
- Warning & alarms on display
- Automatic pool winterising and pool opening
- Diagnostic program and event history for easy maintenance
- Optional Ground connection (part nr 7028037)
- 4 year warranty for cell



Part No.	Type	Price (incl. VAT)
7027993	Low salt chlorinator	
7028417	Flow switch	

If you have separate electrical connections for your Norsup Salt Chlorinator and your pool circulation pump, we recommend that you install a flow switch (part number 7028417) to your Norsup Salt Chlorinator for added protection.



NORSUP AUTOMATIC DOSING SYSTEM

Norsup automatic dosing system is ideal for any private pools up to 100m³. It is easy to install, includes pH & ORP probes, plug & play kit and temperature sensor. A smart, user friendly, LCD interface displays water temp, pH and chlorine levels. The system also offers pH and ORP calibration, a Boost mode for extended hours of chlorine



dosing, Low mode to adjust chlorine dosing in accordance with pool cover operation. It is a great combination to use together with Solem smart module + antenna kit to enjoy wireless control and expanded functionality.

FEATURES

- Great combination with Solem smart module + antenna kit for wireless control and expanded functionality
- PH regulation adjustable from 6.9 to 7.6
- Chlorine concentration & injection limit adjustment 200mV – 900mV
- Real-time counter of injected volume from power on
- Glass probe for PH and ORP
- Warnings & alarms on display
- Diagnostic program and event history for easy maintenance

Part No.	Type	Price (incl. VAT)
7030958	automatic dosing system	

NORSUP 3 YEARS WARRANTY

NORSUP UV DESINFECTATION SYSTEM SUPERNOVA

Norsup Supernova UV disinfection system provides clean, fresh and clear water in an efficient and environmentally friendly manner. Specially designed Duplex housing makes this UV disinfection system suitable for all kinds of pools (Chlor based, salt based, bio pools etc). Norsup has chosen the Amalgam lamp to replace the traditional UV-C lamp in order to ensure a higher, more stable UV-output.

Norsup Supernova Timer is an upgrade of the Norsup Supernova. It has a LED display to indicate the status of the Amalgam lamp. With the timer function you will always know when it is the right time to replace the lamp.



FEATURES

- Provides fresh, clean and clear water
- Efficiently and safely disinfects water
- Amalgam lamp instead of traditional UV-C lamp (for 120W version)
- Flow switch included for 120W model
- Duplex housing suitable for Chlor pool, salt water pool & Bio pools
- Protects your pool against pathogenic organisms
- Keeps the formation of mould, bacteria and algae under control
- Can reduce the use of chlorine and other chemicals by up to 80%
- Prevents chlorine smell and irritation of skin and eyes
- Better for the environment than traditional methods
- Has an electronic ballast for an even power supply
- Straightforward installation and maintenance
- Earthed

NORSUP 3 YEARS WARRANTY

Part No.	Type	Size	Max. pool vol. m ³	Flow m ³	Power W	Price (inc. VAT)
7025376	Supernova 80W	50/63mm x 1 1/2"	65	16	80	
7025377	Supernova 120W	50/63mm x 1 1/2"	90	22	120	
7025378	Supernova Timer 80W	50/63mm x 1 1/2"	65	16	80	
7025379	Supernova Timer 120W	50/63mm x 1 1/2"	90	22	120	

4.6



NORSUP CONTROLLING



NORSUP CONTROL UNIT TYPE NORSUPONE



NorsupOne is an intelligent controller, equipped with sensor and actuator software specifically developed for swimming pools and spas. Each actuator has dedicated digital clock . A series of protocols are used to allow complete automation and management of your pool equipment including push alerts when the system steps outside your desired parameters. NorsupOne allows carefree management of all types of treatment and water balance, filtration,, heating & lighting.



FEATURES

- Wifi controlled via NorsupOne App (available in both Google play & App Store)
- Including PH, ORP, EC and PT100 temperature signals
- Including Modbus protocol and 8 relay signals
- Remote monitoring of pool water chemistry
- Wall mounted box
- Optional 5 relays box (part nr 7028002) to control Norsup EVO+ VSTD

Part No.	Type	Price (incl. VAT)
7028001	Control Unit	





NORSUP CONTROL UNIT & LOW SALT CHLORINATOR PACKAGE

TYPE NORSUPONE

Designed to work in tandem with the Norsup control unit, Norsup relay box and Norsup salt chlorinator. With this Smart package you are able to Wi-Fi control almost all the Norsup pool devices via NorsupOne App meanwhile it manages all types of treatment and water balance.



FEATURES

- Wi-Fi controlled via NorsupOne App (available in both Google play & App Store)
- Including Modbus protocol, 8 relays signals and 5 removable relays
- Remote monitoring of pool water chemistry
- Salt quantity 1.5g/l, Chlorine production 20g/h
- Glass probe for PH and ORP
- PH regulation adjustable from 6.9 to 7.6
- Self-cell cleaning
- Warning & alarms
- Automatic pool winterising and pool opening
- Diagnostic program and event history for easy maintenance
- Optional Ground connection (part nr 7028037)
- 4-year warranty on cell

Part No.	Type	Price (incl. VAT)
7028005	Control Unit & Low salt chlorinator package	

4.7



NORSUP CLEANING

The Norsup Cyclone cleaning robots are designed to clean residential in-ground pools of all sizes and surfaces. Thanks to the patented AquaSmart Gyro System, the Norsup Cyclone will automatically brush, vacuum and micro-filter dirt, debris and contaminants from the pool floor, walls and waterline in a synchronised pattern helping to prevent the cable from tangling.

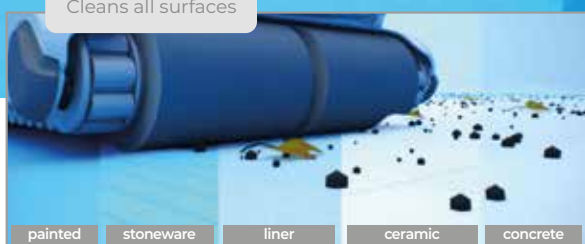

Top loading filter baskets



Anti-Swivel rotary joint



Powerful motor



NORSUP CLEANING ROBOT **CYCLONE X2**



- Cleans and scrubs pool floor, cove, walls and waterline
- Electric swivel
- Powerful suction of 18 m³/h with a third active vibration brush on the bottom of the cleaner
- With a third active vibration brush on the bottom of the cleaner
- Working cycle 1.5hr and 2.5hr
- Cartridge filters down to 20 microns
- Cartridge full - indicator
- Top loading filter baskets with a capacity of around 5 litres (with transparent viewing window)
- AquaSmart Gyro System for intelligent cleaning
- Complete with free caddy
- 18 metre cable
- Repair in our own service centre



NORSUP CLEANING ROBOT **CYCLONE X4**

- Cleans and scrubs pool floor, cove, walls and waterline
- Dual drive motor for much better coordinated cleaning
- Electric swivel
- Powerful suction of 18 m³/h with a third active vibration brush on the bottom of the cleaner
- Smart phone app controlled to spot-clean, hard-to-reach areas
- Multi-Cycle cleaning programs (1.5hr floor only, 2hr and 2.5hr)
- Cartridge filters down to 5 microns
- Cartridge full - indicator
- Top loading filter baskets with a capacity of around 5 litres (with transparent viewing window)
- AquaSmart Gyro System for intelligent cleaning
- Complete with free caddy
- 23 metre cable
- Repairs in our own service centre



NORSUP 4 YEARS WARRANTY

Part No.	Type	Max. pool vol. m ³	Price (incl. VAT)
7027049	Cyclone X2 foam roller	100	
7027050	Cyclone X4 foam roller	150	
7030698	Cyclone X2 brush roller	100	
7030699	Cyclone X4 brush roller	150	

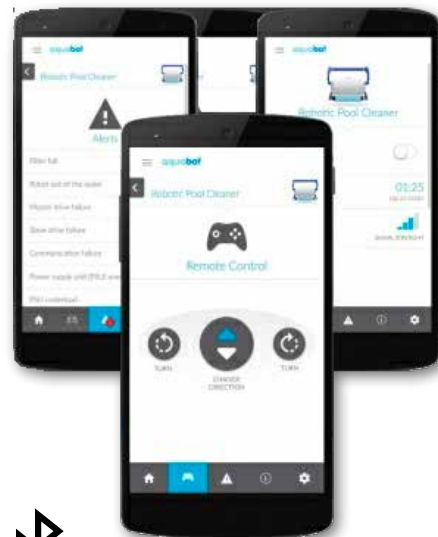

✶ **BLUETOOTH**

With the Bluetooth App you can now program and control your Norsup Cyclone X4 with a simple push of a button. In a few minutes your Norsup Cyclone X4 power supply is connected to your smart phone and you'll be able to customise its features and control it remotely.



3D FABRIC FILTER



4 times better aggregation than Mesh filter



3D fabric to avoid clogs



Up to 5 microns particles
Maximum water filtration



4.8



NORSUP MAINTANANCE ACCESSOIRES



NORSUP **ALGAE BRUSH**



FEATURES

- Superior pool maintenance
- Extra heavy duty construction
- Quick telepole connect/disconnect
- TPR edge to minimise damaging of the pool during maintenance
- Wall-saving side brushes
- Ideal for concrete pools

Part No.	Type	Price (incl. VAT)
7030263	Algae brush	

NORSUP **VACUUM HEAD**



FEATURES

- Superior pool maintenance
- Extra heavy duty construction
- Quick telepole connect/disconnect
- TPR edge to minimise damaging of the pool during maintenance
- Wall-saving rotating side wheels

Part No.	Type	Price (incl. VAT)
7030264	Vacuum head	

NORSUP TRIVAC VACUUM HEAD



FEATURES

- Superior pool maintenance
- Extra heavy duty construction
- Quick telepole connect/disconnect
- TPR edge to minimise damaging of the pool during maintenance

Part No.	Type	Price (incl. VAT)
7030268	TriVac Vacuum head	

NORSUP LEAF SKIMMER



FEATURES

- Superior pool maintenance
- Extra heavy duty construction
- Quick telepole connect/disconnect
- TPR edge to minimise damaging of the pool during maintenance

Part No.	Type	Price (incl. VAT)
7030265	Leaf skimmer	

NORSUP DEEP BAG LEAF RAKE



FEATURES

- Superior pool maintenance
- Extra heavy duty construction
- Quick telepole connect/disconnect
- TPR edge to minimise damaging of the pool during maintenance

Part No.	Type	Price (incl. VAT)
7030266	Deep bag leaf rake	

NORSUP WALL BRUSH



FEATURES

- Superior pool maintenance
- Extra heavy duty construction
- Quick telepole connect/disconnect
- TPR edge to minimise damaging of the pool during maintenance
- Wall-saving rotating side brushes

Part No.	Type	Price (incl. VAT)
7030267	Wall brush	

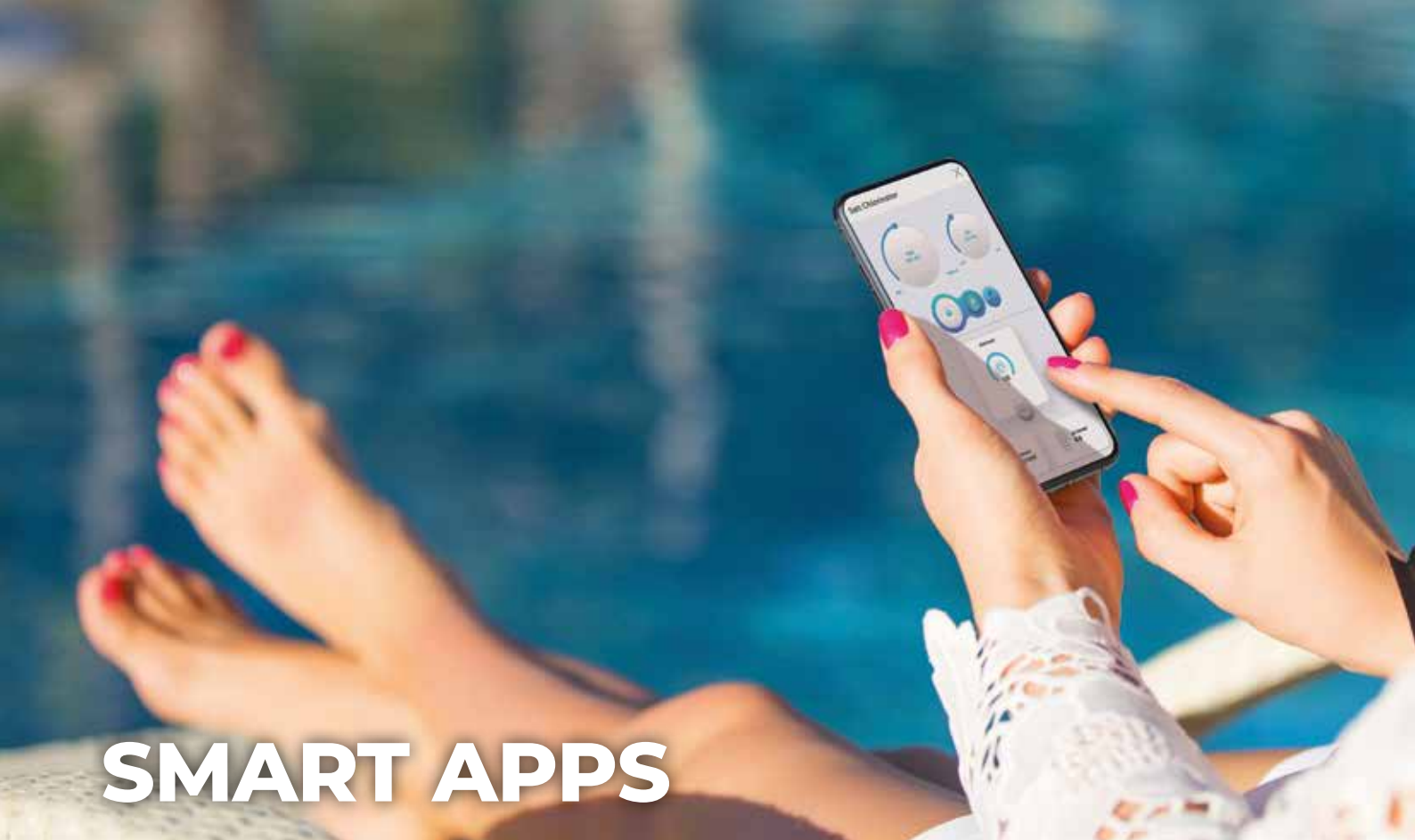

SMART APPS

NORSUP SMART & CONVENIENT

By developing special apps, Norsup makes pool enjoyment very easy for your customers and pool maintenance easy for you.



Norsup Heat Pump Configurator

The Norsup Heat Pump Configurator is a mobile application that helps you to find the most suitable heat pump for your customer. The app gives a heat pump advice based on location, desired water temperature and volume of the pool. You also have the option to evaluate the energy cost of the proposed heat pump(s).



NorsupOne app

NorsupOne is a platform for controlling and automating swimming pool components such as pool pump, heat pump, salt chlorinator and lights from your phone, using the Norsup Controller. Your customer can control his pool from the palm of his hand. As a Norsup dealer, the app can be customised with your logo, so you are just one click away from your customers. Future updates include remote control for installers and maintenance alerts. This will help you offer an improved maintenance service to your customers. The app also includes warranty registration for all Norsup products.



You can download both apps from the Appstore or Play Store. For more information on the use of these apps, check the video's on our Youtube channel:
www.youtube.com/channel/UCKGASs_5dUga_u85f7gO4AA Or contact our sales team.

In 2021 we will continue the development of the NorsupOne app with additional convenient solutions.

WARRANTY

NORSUP NO WORRIES WARRANTY

To ensure your customers' infinite pool enjoyment, we offer your customer at least 3 years of warranty on Norsup products* when registered online at www.norsup.eu. On some products and with some services the warranty period is even longer.

WHAT IS THE 'NO WORRIES WARRANTY'?

You and your customers need to be able to depend on Norsup. Products need to be installed easily and installations can't be out of service for a long time during the swimming season. Norsup understands that. That is why we handle all questions and complaints with priority. We try to solve problems as fast as possible by providing you with the needed materials or even an on-site repair service when necessary. Of all Norsup products, the spare parts can be delivered from stock.

 **NORSUP 3 YEARS WARRANTY**

Products	Warranty	Parts	Labour	Transport	Onsite Repair
 NORSUP	3	✓	✓	✓	✓
Fiberglass pool	3	✓	✓	✓	✓
· Construction	15	✓	✓	✓	✓
· Osmosis	7	✓	✓	✓	✓
PE/PP pools	3	✓	✓	✓	✓
· Construction	15	✓	✓	✓	✓
Pool cover drive system	3	✓	✓	✓	✓
Slat cover	3	✓	✓	✓	✓
Pool roof	3	✓	✓	✓	✓
· Construction	10	✓	✓	✓	✓
Heat pump	4	✓	✓	✓	✓
· Compressor	10	✓	✓	✓	✓
· Heat exchanger	10	✓	✓	✓	✓
Filters	3	✓	✓	✓	
· Valve	5	✓	✓	✓	
· Tank	10	✓	✓	✓	
Pool pumps	4	✓	✓	✓	
Supernova UV lamp	3	✓	✓	✓	
Cyclone cleaner	4	✓	✓	✓	
Salt chlorinator	3	✓	✓	✓	
· Cell	4	✓	✓	✓	
Automatic dosing system	3	✓	✓	✓	
Control unit	3	✓	✓	✓	
Maintenance accessories	3			✓	

* On product and factory mistakes. Consequential and installation damages are never compensated.







Norsup catalogue 2021 UK

Powered by
bosta bevo
bringing water to life

NORSUP